

KITCHENS IN JAZZ

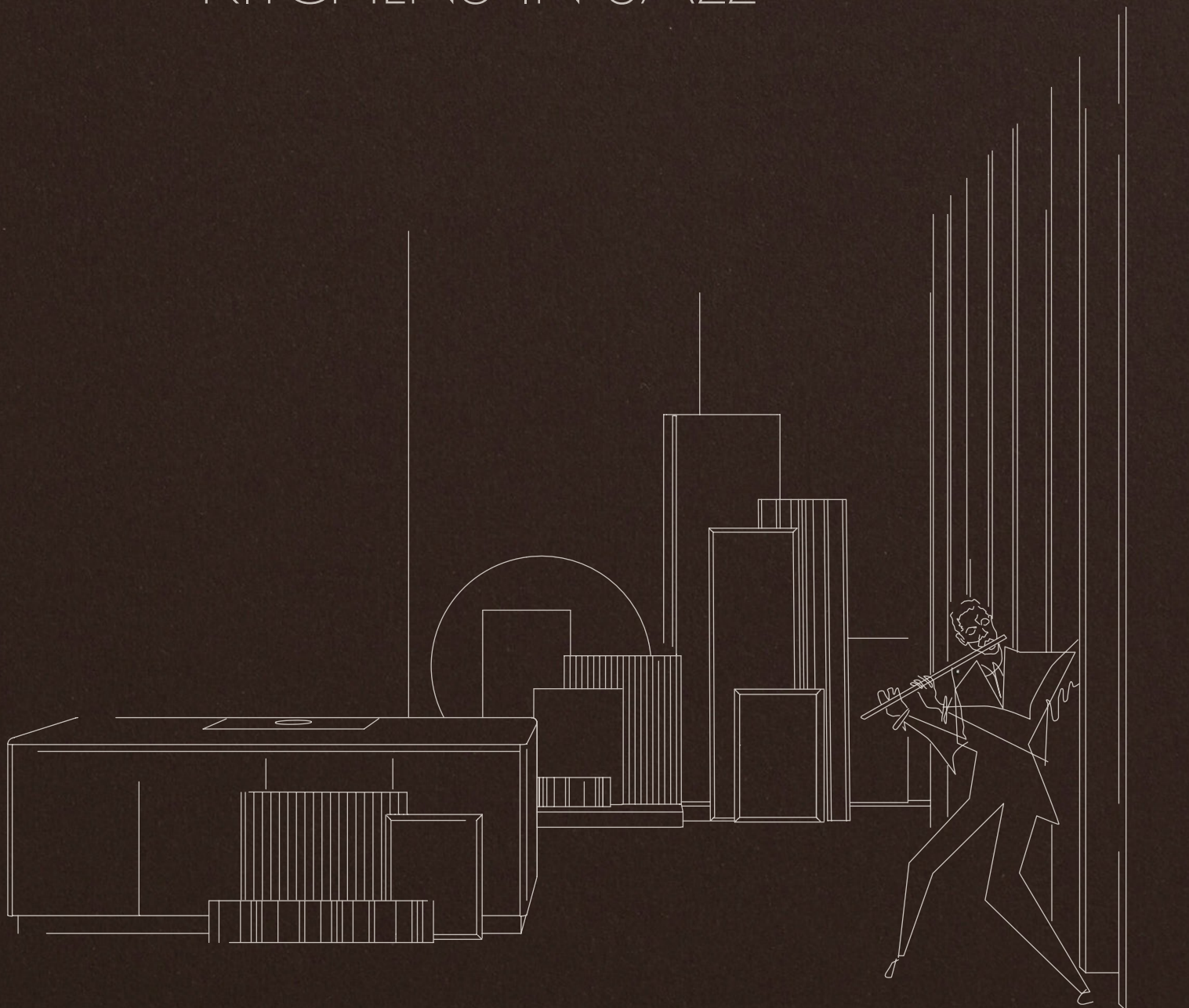

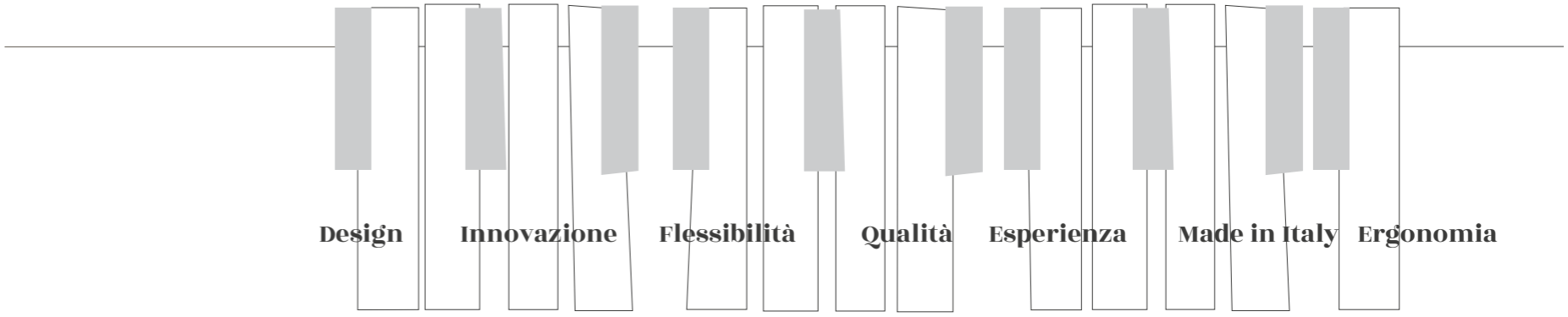
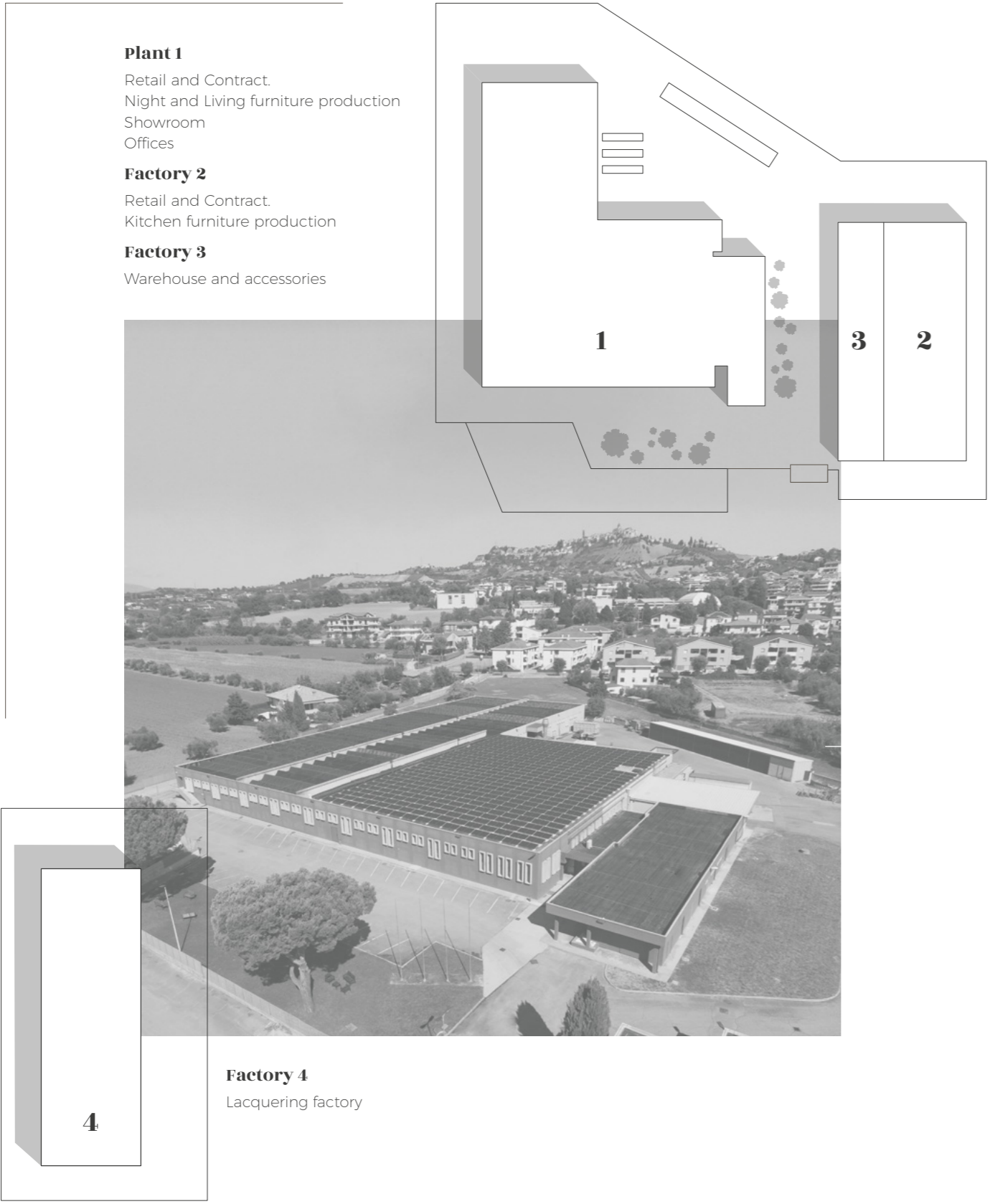

Il brand GF Interiors by Guzzini e Fontana nasce dall'incontro di **Luca Guzzini**, già Presidente della Teuco Guzzini, e **Gary Fontana**, titolare di OC Shanghai, due imprenditori con una lunga e consolidata esperienza nel settore dell'arredamento. In seguito, Luca Guzzini ha concluso il suo percorso all'interno dell'azienda, che oggi continua il suo cammino sotto la leadership di Gary Fontana e una nuova compagine sociale. Nei suoi dieci anni di storia, l'azienda ha vissuto una crescita straordinaria, raggiungendo traguardi importanti, partecipando a numerose edizioni del Salone del Mobile di Milano e consolidandosi con forza sul mercato italiano. Inoltre, GF Interiors esporta quasi in tutto il mondo, offrendo non solo mobili, ma **un vero e proprio lifestyle per la casa**, che unisce design italiano, cura artigianale e innovazione. La filiera produttiva di GF Interiors è completamente interna: l'azienda utilizza macchinari 4.0 per la lavorazione di pannelli in legno, materiali correlati e alluminio, e dispone di una linea automatica dedicata alla verniciatura. Il concetto alla base della filosofia di GF Interiors è **Made with Love in Italy** e racchiude passione nella selezione dei materiali, cura nelle lavorazioni artigianali, attenzione per i dettagli e alta capacità tecnica per un prodotto dal marcato carattere sartoriale.

GF Interiors by Guzzini e Fontana was born from the meeting of **Luca Guzzini**, former President of Teuco Guzzini, and **Gary Fontana**, owner of OC Shanghai—two entrepreneurs with a long and consolidated experience in the furniture sector. Subsequently, Luca Guzzini concluded his journey within the company, which now continues under the leadership of Gary Fontana and a new shareholder structure. Over its ten-year history, the company has experienced extraordinary growth, reaching important milestones, participating in numerous editions of the Salone del Mobile in Milan, and establishing a strong presence in the Italian market. In addition, GF Interiors exports to almost the entire world, offering not just furniture but **a true lifestyle for the home**, blending Italian design, artisanal care, and innovation. The production chain of GF Interiors is entirely in-house: the company uses 4.0 machinery for working with wood panels, related materials, and aluminum, and it has its own automated painting line. The concept underlying the philosophy of GF Interiors is **Made with Love in Italy** and contains passion in the selection of materials, care in craftsmanship, attention to detail and high technical capacity for a product with a marked sartorial character.

Factory

La cura in ogni dettaglio, l'anima del Made in Italy

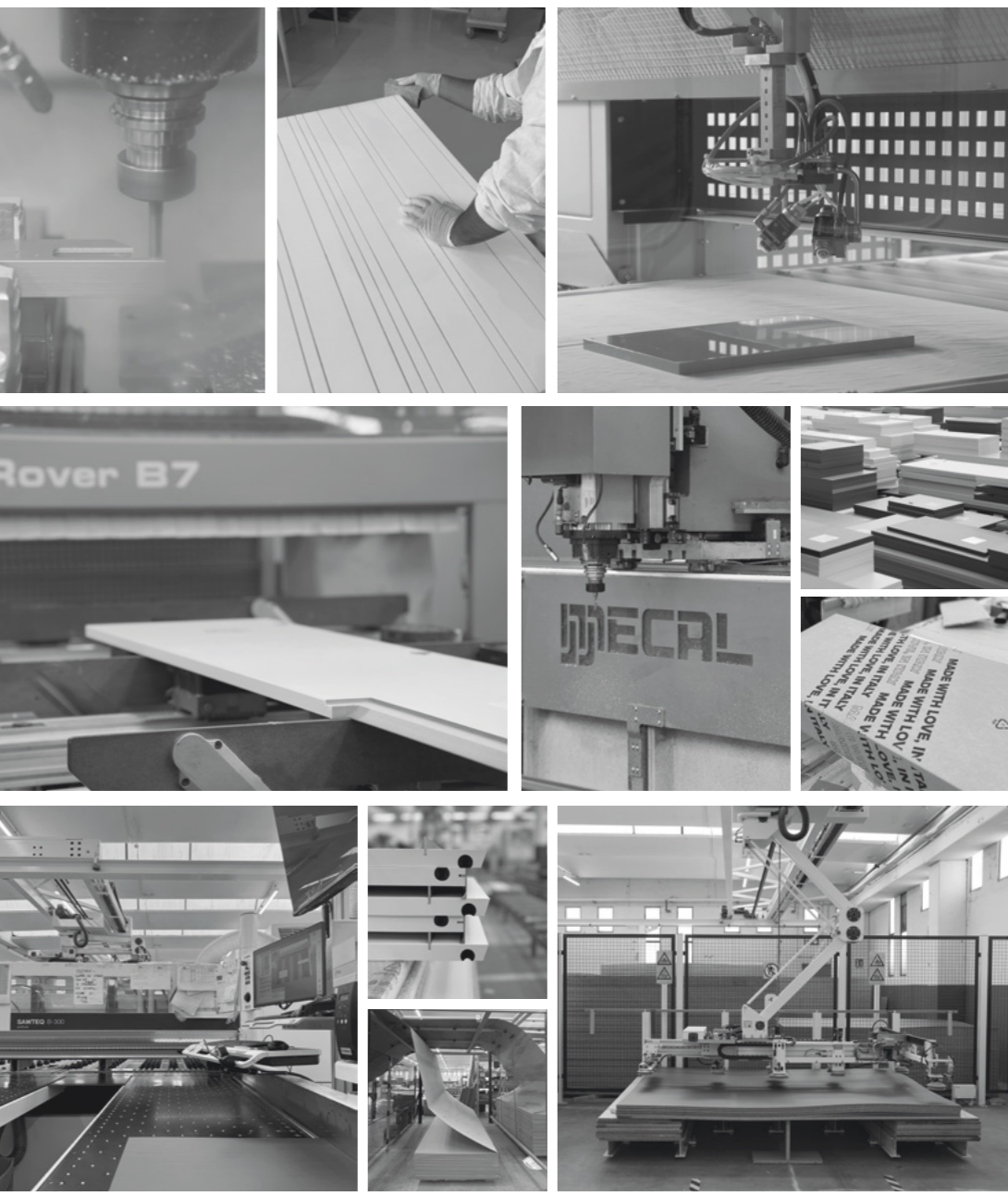
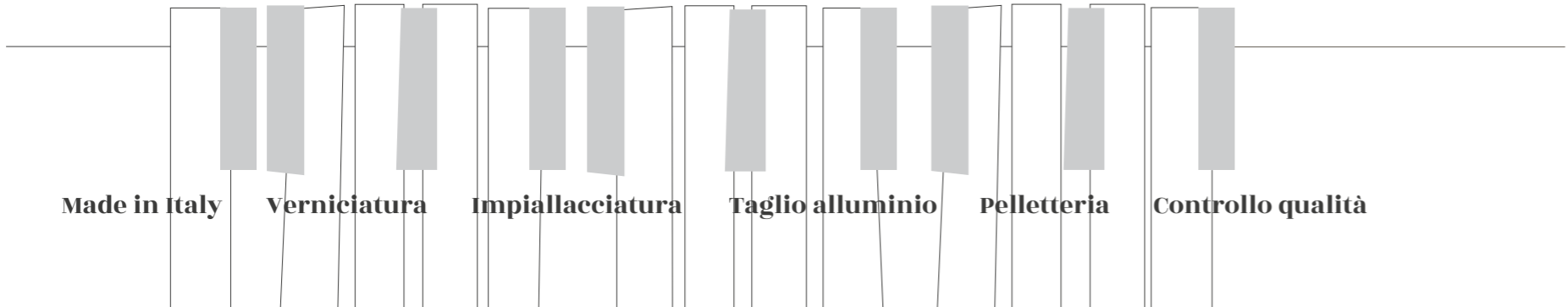

Siamo un'azienda fondata sulla **coesione, sullo spirito di squadra e sulla valorizzazione delle competenze individuali**. La nostra produzione completamente interna garantisce un autentico **Made in Italy**: ogni dettaglio nasce da cura artigianale, ricerca e qualità. Funzionalità ed estetica guidano sistemi e collezioni, pensati per rispondere alle esigenze dell'abitare contemporaneo. Sono questi principi ad orientare la nostra visione e a spingerci a guardare sempre avanti, per **offrire ai nostri clienti soluzioni innovative e di eccellenza**.

We are a company founded on **cohesion, team spirit, and the enhancement of individual skills**. Our fully in-house production ensures authentic **Made in Italy**: every detail is born from artisanal care, research, and quality. Functionality and aesthetics guide the design of systems and collections created to meet the needs of contemporary living. These principles shape our vision and drive us to look ahead, **offering our clients innovative and excellent solutions**.

GF Interiors by Guzzini e Fontana amplia la propria visione introducendo un **progetto cucina** in totale continuità con la zona notte e giorno. Un concept che unifica gli spazi e crea un **total look riconoscibile**, ispirato a un autentico **Jazz Lifestyle**, dove le molteplici finiture del marchio dialogano tra loro in un equilibrio visivo fluido ed elegante. I dettagli iconici si fondono in un **unica linea estetica personale e identitaria**, mentre le **finiture**, pensate per essere **trasversali**, permettono una progettazione dinamica e contemporanea. Nasce così un **idea di casa armonica** e coordinata, firmata GF Interiors.

GF Interiors by Guzzini and Fontana expands its vision by introducing a **kitchen project** that flows seamlessly into the sleeping and living areas. A concept that unifies spaces and creates a **distinctive total look**, inspired by an authentic **Jazz Lifestyle**, where the brand's multiple finishes interact with each other in a fluid and elegant visual balance. Iconic details merge into a **unique aesthetic line with a personal identity**, while the finishes, designed to be versatile, allow for dynamic and contemporary design. The result is a **harmonious and coordinated home concept**, designed by GF Interiors.

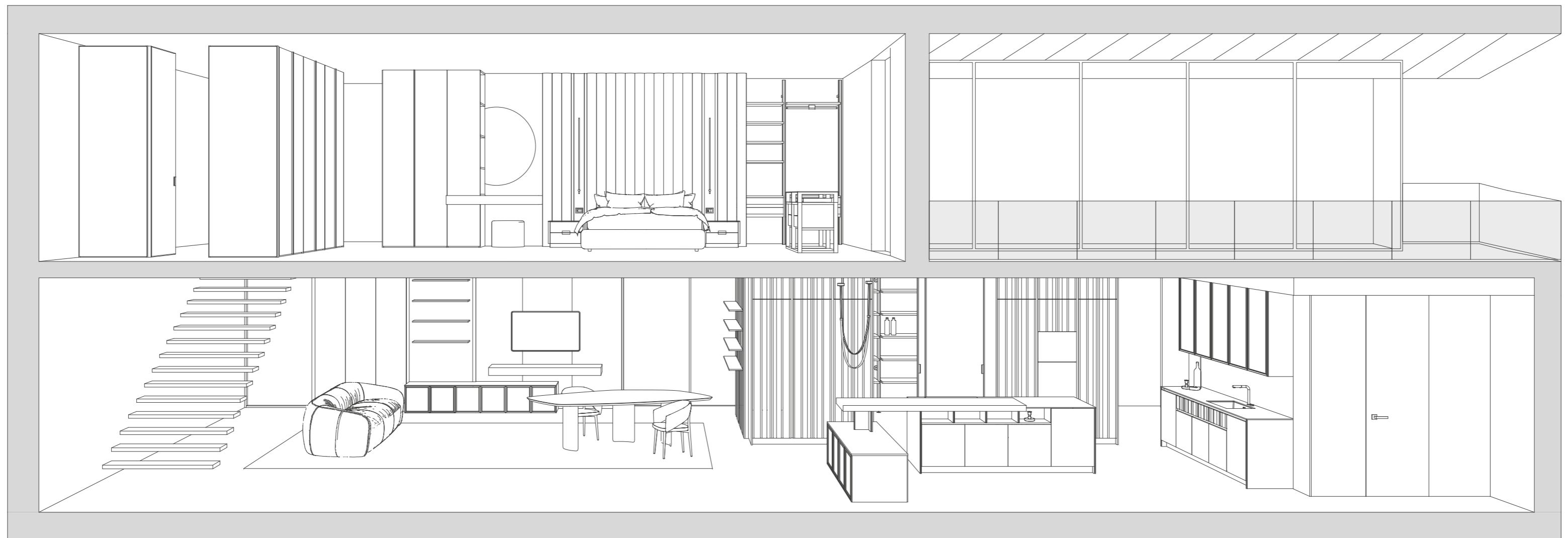

Una cucina, infinite possibilità

GF Interiors by Guzzini e Fontana amplia il proprio orizzonte creativo e dà vita a **Kitchens in Jazz**, la nuova collezione cucine che completa il percorso iniziato con la zona notte e living. Un progetto che nasce dal desiderio di **disegnare ambienti connessi**, dove ogni spazio dialoga con l'altro in un linguaggio fluido, coerente e naturale, estendendo la propria visione dell'abitare fino alla **cucina**, cuore pulsante della casa e luogo d'incontro tra estetica e funzionalità.

Come nel jazz, ogni nota trova senso nella relazione con le altre così la cucina diventa **parte integrante di una sinfonia domestica**, in cui materiali, volumi e tonalità si muovono all'unisono.

Le linee pulite del modello **Flat** aprono la collezione, riprendendo **finiture e materiali già iconici** del mondo GF Interiors per reinterpretarle in chiave cucina e realizzare una continuità estetica che unisce zona giorno, notte e ambiente cucina sotto un'unica firma e visione di design contemporaneo.

Kitchens in Jazz è molto più di un progetto d'arredo: è una filosofia abitativa che invita a vivere ogni ambiente come parte di un'unica composizione, un **progetto di continuità stilistica** nel segno dell'armonia, della libertà e del design.

GF Interiors by Guzzini e Fontana expands its creative horizon and gives life to **Kitchens in Jazz**, the new kitchen collection that completes the journey begun with the night and living lines. A project born from the desire to **design connected environments**, where every space communicates with the others through a fluid, coherent, and natural language — extending its vision of living to the **kitchen**, the beating heart of the home and the meeting point between aesthetics and functionality.

Just like in jazz, where each note finds meaning through its relationship with the others, the kitchen becomes an **integral part of a domestic symphony** in which materials, volumes, and tones move in harmony.

The clean lines of the **Flat** model open the collection, reinterpreting the **iconic finishes and materials** of the GF Interiors world in a kitchen context, creating an aesthetic continuity that unites day, night, and kitchen areas under one signature and one vision of contemporary design.

Kitchens in Jazz is much more than a furniture project: it is a living philosophy that invites you to experience every space as part of a single composition — a **project of stylistic continuity** defined by harmony, freedom, and design.

Il cuore attorno a cui prende vita la casa



P. 12 - 29



FLAT CRIMSON LAKE

1th STORY

P. 30 - 47



FLAT CAPPUCCINO

2nd STORY

P. 64 - 79



FLAT COSMIC

4th STORY

P. 80 - 95



FLAT DEEP HAVANA

5th STORY

P. 48 - 63



FLAT MERCURIO

3th STORY

P. 96 - 113



FLAT SAHARA BG

6th STORY

P. 114 - 131



SKINNY ROVERE CLOUD

7th STORY

“Il jazz non morirà mai, finché ci sarà qualcuno disposto a rischiare una nota sbagliata.”

Cit. Thelonious Monk

1th STORY

FLAT CRIMSON LAKE

Avolto dal vibrante Crimson Lake, l'ambiente è un'armonia di volumi, materia e luce. L'isola centrale, complessa e scenografica, combina il volume tecnico del piano cottura con il piano snack sospeso e le vetrine basse, interpreti di trasparenza spaziale. Il colonnato retrostante accoglie una porta vetrata, varco verso una seconda area operativa e dispensa. A sinistra, la zona lavaggio si alleggerisce con pensili vetrina, mentre la luce naturale, filtrando dal grande lucernario, amplifica il contrasto tra il calore del Rovere Termotrattato e la profondità del Crimson Lake. Boiserie e rivestimenti coordinati, leitmotiv dell'intero ambiente, connettono i diversi volumi in una continuità architettonica elegante e misurata. Linee continue, trasparenze e materiali pregiati definiscono uno spazio che unisce cucina e living in un'unica, raffinata composizione architettonica.

Wrapped by vibrant Crimson Lake, the space is a harmony of volumes, material, and light. The central island, complex and scenographic, combines the technical volume of the cooktop with the suspended snack counter and low display units, interpreters of spatial lightness. The rear column system accommodates a glass door, a passage to a secondary working area and pantry. On the left, the washing area is lightened with glass-front wall cabinets, while natural light, filtering through the large skylight, amplifies the contrast between the warmth of Thermo-Treated Oak and the depth of Crimson Lake. Coordinated boiserie and wall coverings, leitmotiv of the entire space, connect the different volumes in an elegant and measured architectural continuity. Continuous lines, transparency, and fine materials define a space that unites kitchen and living into a single, refined architectural composition.

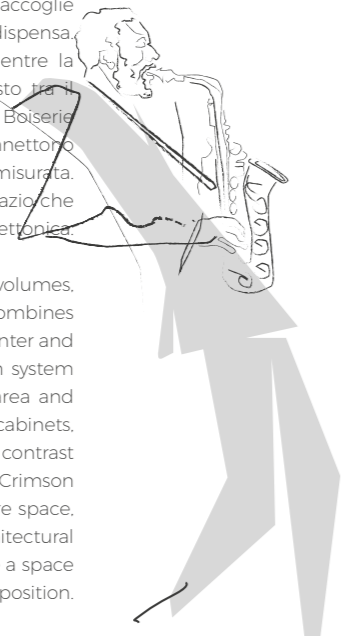

Kitchens in Jazz



First story, Flat Crimson Lake





L'isola cucina Flat, in laccato opaco color Crimson Lake, è completata da un piano snack a forte spessore in Rovere TC, appoggiato su di essa. Le basi a terra, con struttura in bilaminato finitura Mandorlo e ante Evans Air in alluminio Bronzo e vetro Fumè, creano un insieme coerente e raffinato. Alle spalle dell'isola, il colonnato Flat in impiallacciato Rovere TC con riga Tempo è intervallato dalla porta con anta E.S.P. Cristal, che dona leggerezza e continuità visiva all'ambiente.

The Flat kitchen island, finished in matte Crimson Lake lacquer, is complemented by a thick snack top in Rovere TC resting elegantly upon it. The floor-standing base units in Mandorlo bilaminated and Evans Air doors in Bronzo aluminum and Fumè glass, create a refined and harmonious composition. Behind the island, the Flat columns in Rovere TC ribbed wood veneer Tempo detail is interrupted by the E.S.P. Cristal door, adding lightness and visual continuity to the space.





Isola modello Flat laccata opaca Crimson Lake con fianco Misty impreziosito da inserto in alluminio Bronzo, dettaglio ripreso anche nel modulo a giorno Misty in legno Rovere TC. La zona lavaggio a parete presenta basi in finitura mista Crimson Lake liscio e riga Tempo, abbinata a pensili vetrina Evans Air con telaio in alluminio Bronzo e struttura in bilaminato Mandorlo. Piano di lavoro in gres Midnight black opaco, spessore 12 mm.

Flat model Matt lacquered Crimson Lake island with Misty side panel with a Bronzo aluminum insert, a detail reintroduced in the open Misty module in Rovere TC wood veneer finish. The washing area features base units in a mix of smooth Crimson Lake doors and ribbed Tempo drawers, combined with Evans Air glass wall units with Bronzo aluminum frame and Mandorlo bilaminated structure. Worktop in matt Midnight black gres, 12 mm thick.



First story. Flat Crimson Lake



Particolare del colonnato Flat in legno Rovere TC con inserto Tempo e porta scorrevole E.S.P. Cristal con vetro fumé. Dispensa Sky8 in alluminio nero con illuminazione LED verticale e mensole in bilaminato Mandorlo. Cucina secondaria realizzata in Flat Super Matt Grey EX e Black EX. Piano di lavoro e schienale in gres Midnight black opaco, spessore 12 mm.

Detail of the Flat column module in Rovere TC wood with ribbed Tempo and E.S.P. Cristal sliding door with Fumè glass. Sky8 storage units in Black aluminum with vertical LED lighting and shelves in Mandorlo bilaminated. Secondary kitchen in Flat Super Matt Grey EX and Black EX finishes. Worktop and backsplash in matt Midnight black gres, 12 mm thick.



Technical data

1th STORY

1



FLAT LACCATO OPACO CRIMSON LAKE
 FLAT TEMPO LEGNO IMPIALLACCIATO ROVERE TC
 EVANS AIR ALLUMINIO BRONZO VETRO FUMÈ
 WORKTOP GRES MIDNIGHT BLACK 12MM
 GOLA E ZOCCOLO ALLUMINIO BRONZO

Dimensione totale colonne H 265 L 560,4 cm
 Colonne H 216 cm, Sopracolonna H 39 cm
 Zoccolo H 10 cm
 Boiserie e boiserie sporgente H 265 cm
 Dimensione totale basi e pensili H 265 L 304,4 cm
 Basi H 81, Pensili H 117 cm
 Dimensione totale isole H 92,2 L 244,4 cm
 Isola H 92,2 L 360 cm
 Basi h 81 cm, Zoccolo H 10 cm
 Basi vetrine a terra H 58,5 cm
 Worktop sp. 1,2 cm
 Piano Folding sp. 12 cm

Dimensione totale cucina H 265 L 240 cm
 Basi gola H 81, Pensili H 117 cm
 Zoccolo H 10 cm
 Worktop sp. 12 cm
 Dispensa Sky8 a parete H 265 L 287 cm



FLAT SUPER MATT ECCIMERI BLACK EX
 FLAT SUPER MATT ECCIMERI GREY EX
 MENSOLE BILAMINATO LEGNO MANDORLO

2

3



TEMPO LACCATO OPACO MERCURIO
 LEGNO IMPIALLACCIATO ROVERE TC
 EVANS AIR ALLUMINIO NERO VETRO FUMÈ
 GRES MIDNIGHT BLACK 12MM
 LACCATO OPACO GOFFRATO NERO

Dimensione totale Living H 275,5 L 460 cm
 Bussolotti alti H 275,5 cm
 Basi vetrine a terra H 58,5 cm
 Boiserie H 215,8 e 275,5 cm
 Piano Folding H 12 L 200 cm
 Tavolo Yass L 280 cm

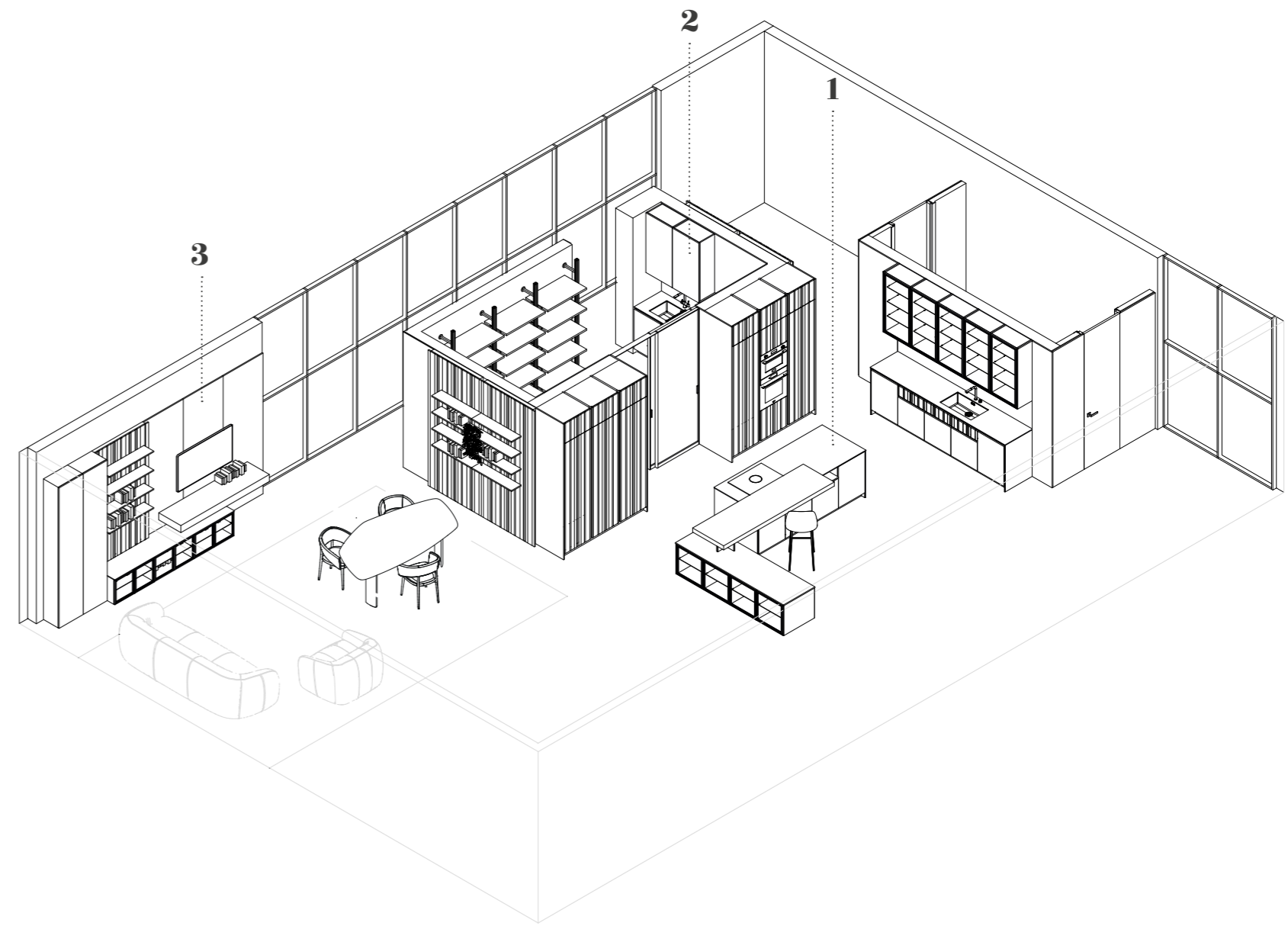

Geometrie Domestiche

1th STORY



Colonne H 235.5
 Basi gola H 81
 Pensili H 97.5
 Zoccolo H 10

FLAT TEMPO LACCATO OPACO CRIMSON LAKE
 FLAT TEMPO LEGNO IMPIALLACCIATO ROVERE TC
 EVANS AIR ALLUMINIO NERO VETRO FUMÉ
 WORKTOP GRES MIDNIGHT BLACK SP 12 MM
 GOLA E ZOCCOLO ALLUMINIO BRONZO

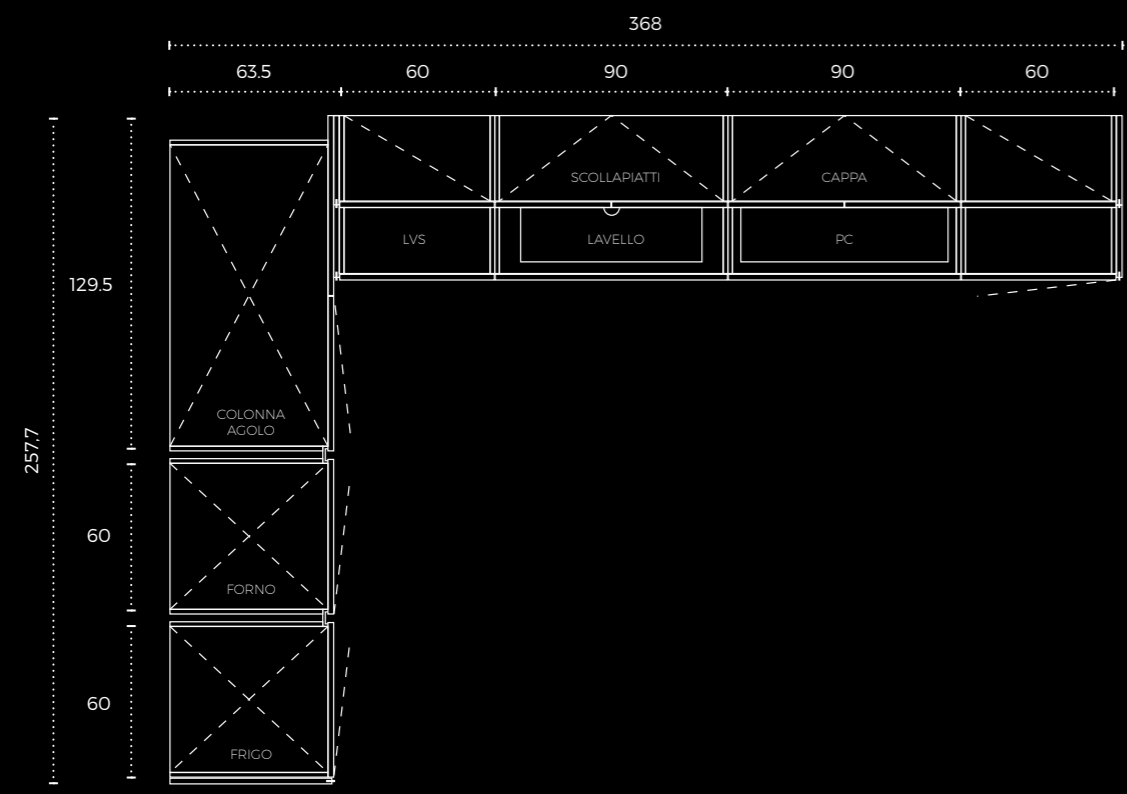

Flat Crimson Lake

“Io non recito la malinconia, la porto dentro. Quando suono, non cerco bellezza: cerco una tregua.”

Cit. Chet Baker

FLAT CAPPUCINO **2nd** STORY

Un progetto dallo spirito architettonico, pensato come spazio fluido e integrato, dove cucina e living si fondono in un'unica visione continua. Il blocco tecnico, incassato a parete, è concepito come un'architettura nella stanza: nicchie e piani si alternano accogliendo la zona operativa, la zona bar ed il living in un equilibrio raffinato. L'isola, definita dal pregio del legno rigato Grigio Londra e dalle trasparenze del vetro, diviene elemento di connessione e ricercata centralità, un segno di misura e profondità visiva. Sullo sfondo, le vetrine Evans in laccato Forest Green, di un'eleganza nobile e senza tempo, introducono una nota distintiva che esalta il carattere esclusivo. L'alternanza dei materiali, la trama delle superfici ed i giochi di luce definiscono un ambiente dove ogni elemento concorre ad un equilibrio sofisticato, pensato come luogo di incontro fra innovazione, accoglienza e funzione.

A project with an architectural spirit, conceived as a fluid, integrated space where kitchen and living merge into a single continuous vision. The technical block, recessed into the wall, is designed as an architecture within the room: niches and planes alternate, accommodating the work area, the bar area, and the living space in refined balance. The island, defined by Grigio Londra striped wood and the transparency of glass, becomes an element of connection and centrality, a sign of measure and visual depth. In the background, the Evans cabinets in Forest Green lacquer introduce a distinctive note that enhances the exclusive character. The interplay of materials, the texture of surfaces, and the play of light define an overall environment where each element contributes to a beautifully sophisticated harmony, conceived as a space where innovation, hospitality, and functionality come together.

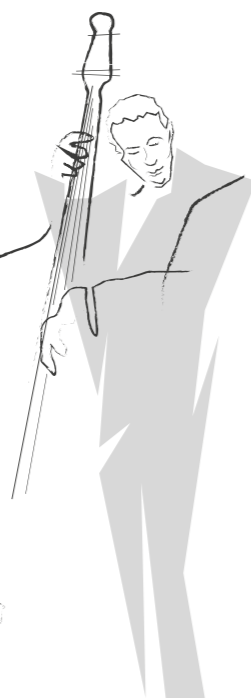

Kitchens in Jazz



Second story. Flat Cappuccino





Isola centrale modello Flat in legno Rovere Grigio Londra rigato Always, abbracciata da vetrine basse Evans Air con telaio in alluminio nero e vetro fumé. Struttura in bilaminato Visone e schienale in finitura bilaminato Travertino. Colonne Flat laccato opaco Cappuccino liscio, abbinato al rigato Always e valorizzate da boiserie sporgente con mensole in bilaminato Travertino con illuminazione LED integrata e boiserie in vetro specchio Fumé.

Central island. Flat model, in ribbed Rovere Grigio Londra Always wood, embraced by low Evans Air glass units with black aluminum frame and Fumé glass. Structure in Visone bilaminated and back panel in Travertino finish. Flat columns in smooth matt Cappuccino lacquer, paired with ribbed Always detailing and enhanced by a projecting Travertino boiserie with LED lighting and mirror Fumé glass panels.



Second story. Flat Cappuccino





Particolare isola con fianchi e pannello retro a sormonto in legno Grigio Londra rigato Always e piano in gres Concrete grey, spessore 12 mm. Sullo sfondo, colonne Flat nello stesso legno Grigio Londra con vetrine attrezzate Evans Air in alluminio nero e vetro Fumé. Intera parete con porta filo muro rivestita da boiserie nello stesso legno Rovere Grigio Londra.

Detail of the island with side panels and overlapping back panel in ribbed Grigio Londra Always wood and 12 mm thick Concrete grey gres worktop. In the background, Flat columns in the same Grigio Londra wood with Evans Air equipped glass units in black aluminum and Fumé glass. Full-height wall with flush-to-the-wall door clad in matching Rovere Grigio Londra wood boiserie.



Dettaglio delle vetrine Evans Air con struttura in bilaminato Mandorlo, illuminazione LED verticale e schiena laccata opaca Forest Green. Cassetti sospesi rivestiti in eco-pelle Corfu Green e mensole in alluminio nero, attrezzate con portacalici e portabottiglie. Colonne Flat con maniglia a ponte in finitura Nero opaco e colonna cantina frigo con apertura push-pull.

Detail of the Evans Air glass units with Mandorlo bilaminated structure, vertical LED lighting, and matt lacquered Forest Green back panel. Suspended drawers upholstered in Corfu Green eco-leather and Black aluminum shelves equipped with glass and bottle holders. Flat columns with bridge handle in matt Black finish and wine cooler column with push-pull opening system.



Technical data

1

FLAT ALWAYS
LACCATO
OPACO
CAPPUCCINO

FLAT ALWAYS
LEGNO
ROVERE GRIGIO
LONDRA

BOISERIE
SPECCHIO
FUMÉ

BOISERIE
BILAMINATO
PIETRA
TRAVERTINO

WORKTOP GRES
CONCRETE GREY
12MM

Dimensione totale colonne H 245.5 L 490.4 cm
Colonne H 235.5 cm, Zoccolo H 10 cm
Base sospesa H 39 cm
Boiserie e boiserie sporgente H 152.5 cm

Dimensione totale colonne H 245.5 L 452.2 cm
Colonne e vetrine H 235.5 cm, Zoccolo H 10 cm
Basi sospese H 39 cm
Boiserie e boiserie sporgente H 50 e 152.5 cm

2

EVANS AIR
ALLUMINIO NERO
VETRO FUMÉ

BILAMINATO
LEGNO
MANDORLO

LACCATO OPACO
VERDE
FORESTA

FLAT
LEGNO
ROVERE GRIGIO
LONDRA

3

LACCATO
OPACO
CAPPUCCINO

LEGNO
IMPIALLACIATO
ROVERE GRIGIO
LONDRA

EVANS AIR
ALLUMINIO NERO
VETRO FUMÉ

BILAMINATO
PIETRA
TRAVERTINO

LACCATO OPACO
GOFFRATO
NERO

Dimensione totale Living H 245.5 L 450 cm
Bussolotti alti e vetrine H 192 cm
Basi a terra H 24 cm
Boiserie H 221.5 e 29.5 cm
Tavolo Yass L 280cm

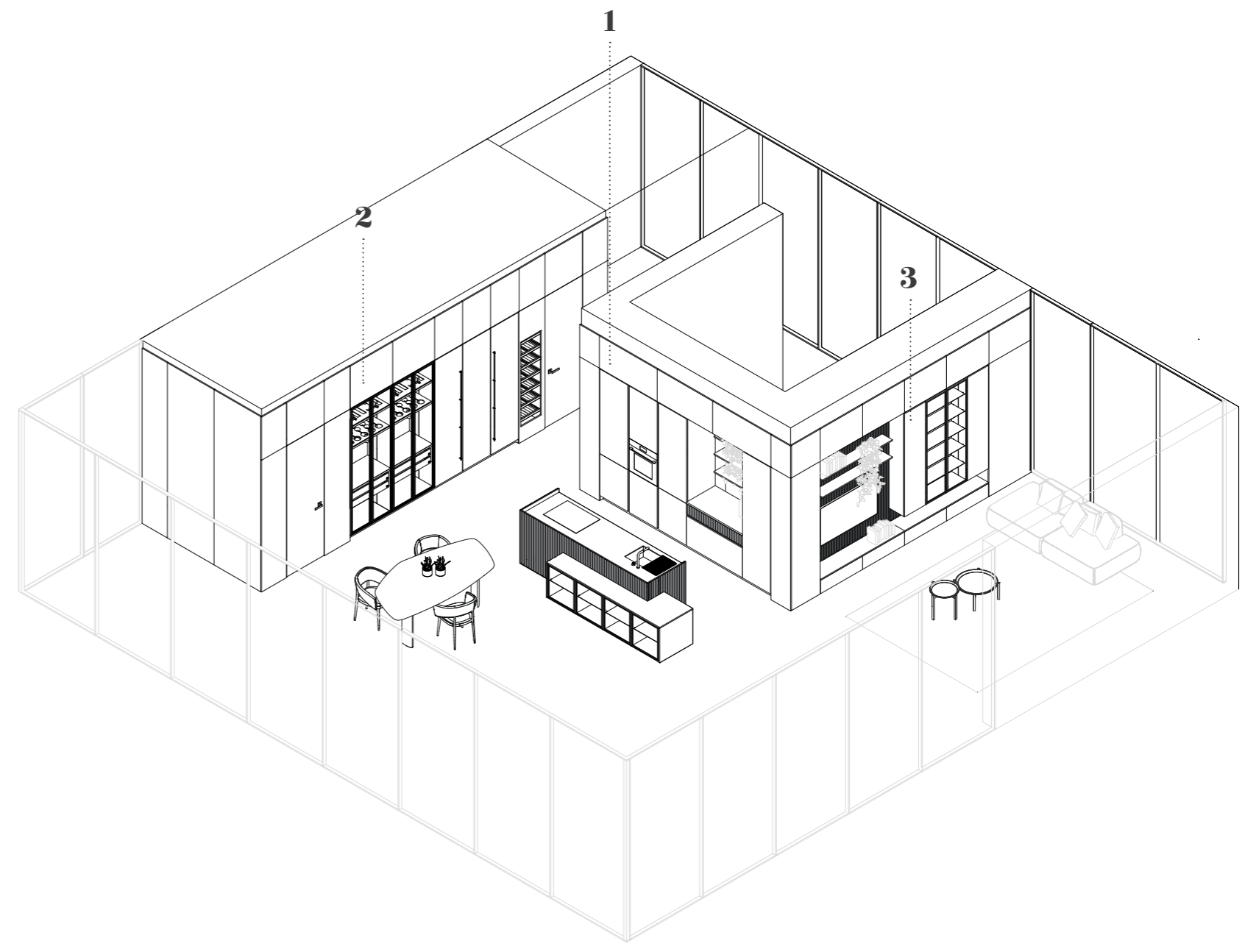

Geometrie Domestiche



Colonne H 235.5
 Basi gola H 81
 Pensili H 97.5
 Zoccolo H 10

FLAT ALWAYS
 LACCATO
 OPACO
 CAPPUCCINO

FLAT ALWAYS
 LEGNO
 ROVERE GRIGIO
 LONDRA

WORKTOP GRES
 CONCRETE GREY
 12MM

GOLA E ZOCCOLO
 ALLUMINIO
 NERO

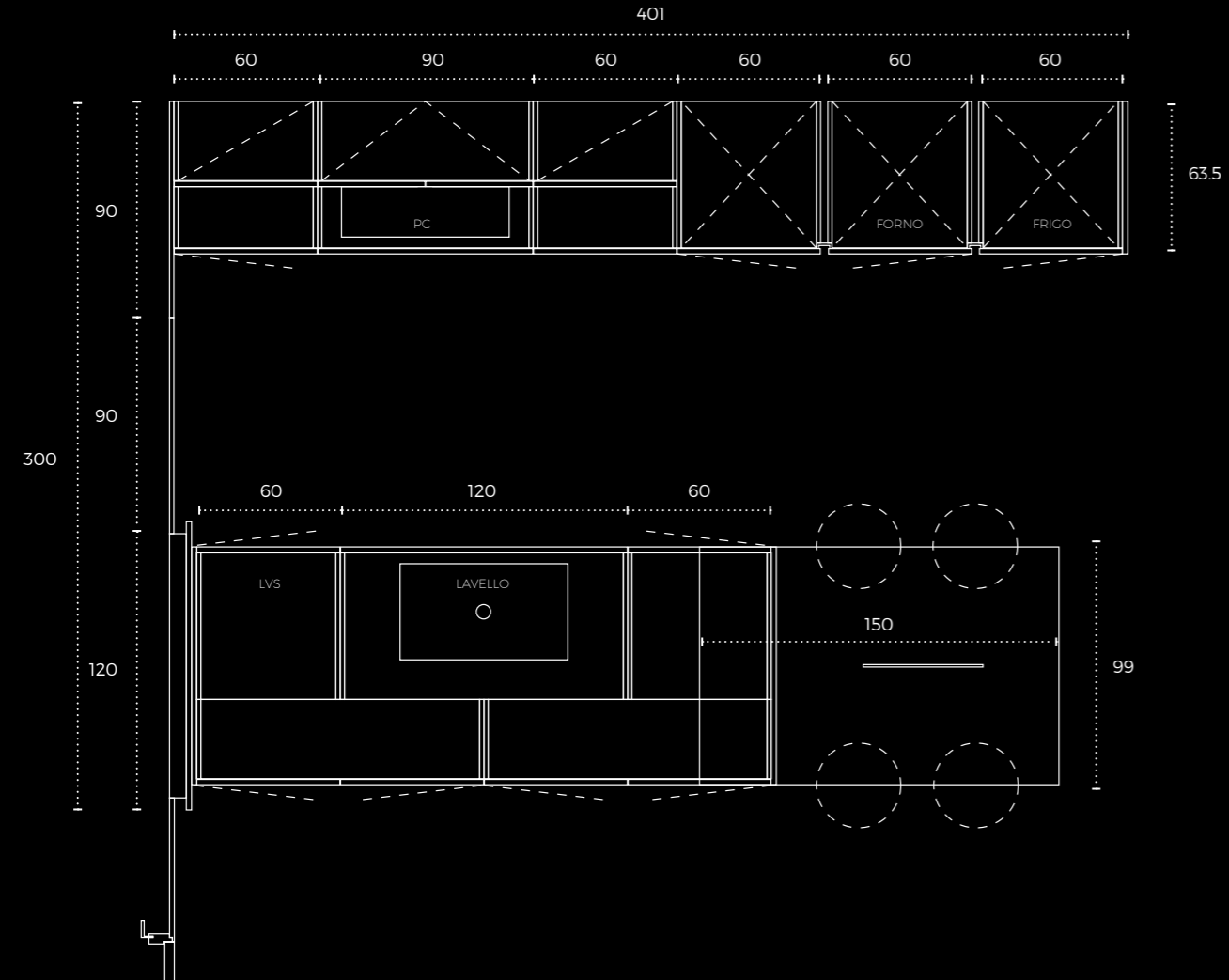

“Cerco nella musica un modo per purificare l’anima. Ogni assolo è una preghiera, un tentativo di raggiungere qualcosa che non ha nome.”

Cit. John Coltrane

3rd STORY

FLAT MERCURIO

L'ambiente si declina come una sinfonia di materie contemporanee e contrasti calibrati, modellato dalla luce dell'ampia apertura superiore. Nel cuore dello spazio, l'isola, con il suo modulo a giorno diagonale Wing, si impone come protagonista elegante e visionaria, fondendo riflessi metallici, legni caldi e venature senza tempo. Alle spalle, il colonnato tecnico crea una quinta discreta e ricercata, interrotta dal ritmo materico della boiserie centrale in Noce Canaletto e Travertino. Vettrine illuminate e boiserie dinamiche alternano trasparenze e superfici piene, invitando a scoprire un ritmo compositivo nuovo ed inatteso. Ogni elemento, dal piano in gres ai giochi di trasparenze, riflette la ricerca di una bellezza dove la funzione si fa forma e la forma si fa emozione.

The space unfolds as a symphony of contemporary materials and measured contrasts, shaped by the light flowing through the large upper opening. At the heart of the composition, the island, featuring the diagonal open Wing module, for the back of the island, stands as an elegant and visionary centerpiece, blending metallic reflections, warm woods, and timeless veining. Behind it, the technical column system creates a discreet and sophisticated backdrop, punctuated by the textural rhythm of the central boiserie in Noce Canaletto wood veneer and Travertino bilaminare. Illuminated display cabinets and dynamic wall panels alternate between transparency and solid surfaces, inviting discovery of a new and unexpected compositional rhythm. Every element — from the stoneware countertop to the play of transparencies — reflects the pursuit of a beauty where function becomes form, and form becomes emotion.

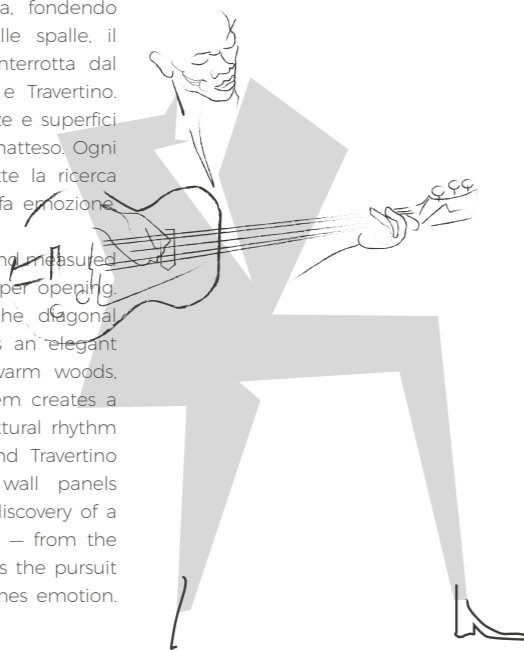

Kitchens in Jazz



Third story. Flat Mercurio





Colonnato tecnico Flat in laccato metallico Mercurio con zoccolo e anta a terra, separato da una base centrale sospesa in legno Noce Canaletto rigato Always, riproposto anche accanto al colonne con vetrine Evans Air in alluminio nero e vetro Fumé. La struttura, con illuminazione LED verticale, è realizzata in bilaminato Visone con schienale in Noce Canaletto e ripiani in vetro Fumé.

Technical Flat columns in metallic lacquered Mercurio finish with plinth and full-height door. In the middle suspended base unit in ribbed Noce Canaletto Always wood veneer, echoed alongside the column system with Evans Air glass units in black aluminum and Fumé glass. The structure with vertical LED lighting, is made of Visone bilaminated with Noce Canaletto back panel and Fumé glass shelves.





Base con gola sospesa in legno Noce Canaletto rigato Always con boiserie sporgente in bilaminato Travertino con illuminazione LED verticale e mensole, affiancata da boiserie in legno Noce Canaletto rigato Always. Colonne Flat in bilaminato Travertino in abbinamento.

Suspended base unit with groove in ribbed Noce Canaletto Always wood. Travertino bilaminated boiserie with vertical LED lighting and shelves, paired with Noce Canaletto Always ribbed wood boiserie. Flat tall units in matching Travertino bilaminated finish.



Isola Flat laccato metallico Mercurio con fianco Misty impreziosito da inserto in alluminio nero e piano di lavoro in gres Bianco alpino con bordo costruito spessore 4 cm. Retroisola diagonale Wing in legno Noce Canaletto con illuminazione LED verticale, abbinata a boiserie laccata metallica Mercurio con inserto Always e mensole coordinate.

Flat island in metallic lacquered Mercurio finish with Misty side panel featuring a black aluminum insert and Bianco alpino gres worktop, 4 cm thick. Diagonal Wing module at the back of the island in Noce Canaletto wood with vertical LED lighting, combined with metallic lacquered Mercurio boiserie featuring Always detailing and matching shelves.



Third story. Flat Mercurio

Technical data

1

FLAT LACCATO METALLICO MERCURIO
 FLAT LEGNO IMPIALLACCIATO NOCE CANALETTO
 BILAMINATO OPACO VISONE
 BILAMINATO PIETRA TRAVERTINO
 WORKTOP GRES BIANCO ALPINO SP 4 CM

Dimensione totale colonne H 245.5 L 490.4 cm
 Colonne H 235.5 cm, Zoccolo H 10 cm
 Base sospesa H 39 cm
 Boiserie e boiserie sporgente H 152.5 cm
 Worktop sp. 4 cm
 Dimensione totale isola H 95 L 304.4 cm
 Basi H 81 cm . Zoccolo H 10 cm

2

Dimensione totale colonne H 245.5 L 452.2 cm
 Colonne e vetrine h 235.5 cm, Zoccolo H 10 cm
 Basi sospese H 39 cm
 Boiserie e boiserie sporgente H 50 e 152.5 cm

EVANS AIR ALLUMINIO NERO VETRO FUMÉ
 LEGNO IMPIALLACCIATO NOCE CANALETTO
 FLAT BILAMINATO PIETRA TRAVERTINO

3

LACCATO OPACO CAPPUCCINO
 LACCATO METALLICO MERCURIO
 EVANS AIR ALLUMINIO NERO VETRO FUMÉ
 BILAMINATO PIETRA TRAVERTINO
 LACCATO OPACO GOFFRATO NERO

Dimensione totale Living H 245.5 L 450 cm
 Bussolotti alti e vetrine H 192 cm
 Basi a terra H 24 cm
 Boiserie H 221.5 e 29.5 cm
 Tavolo Yass Ø 150cm

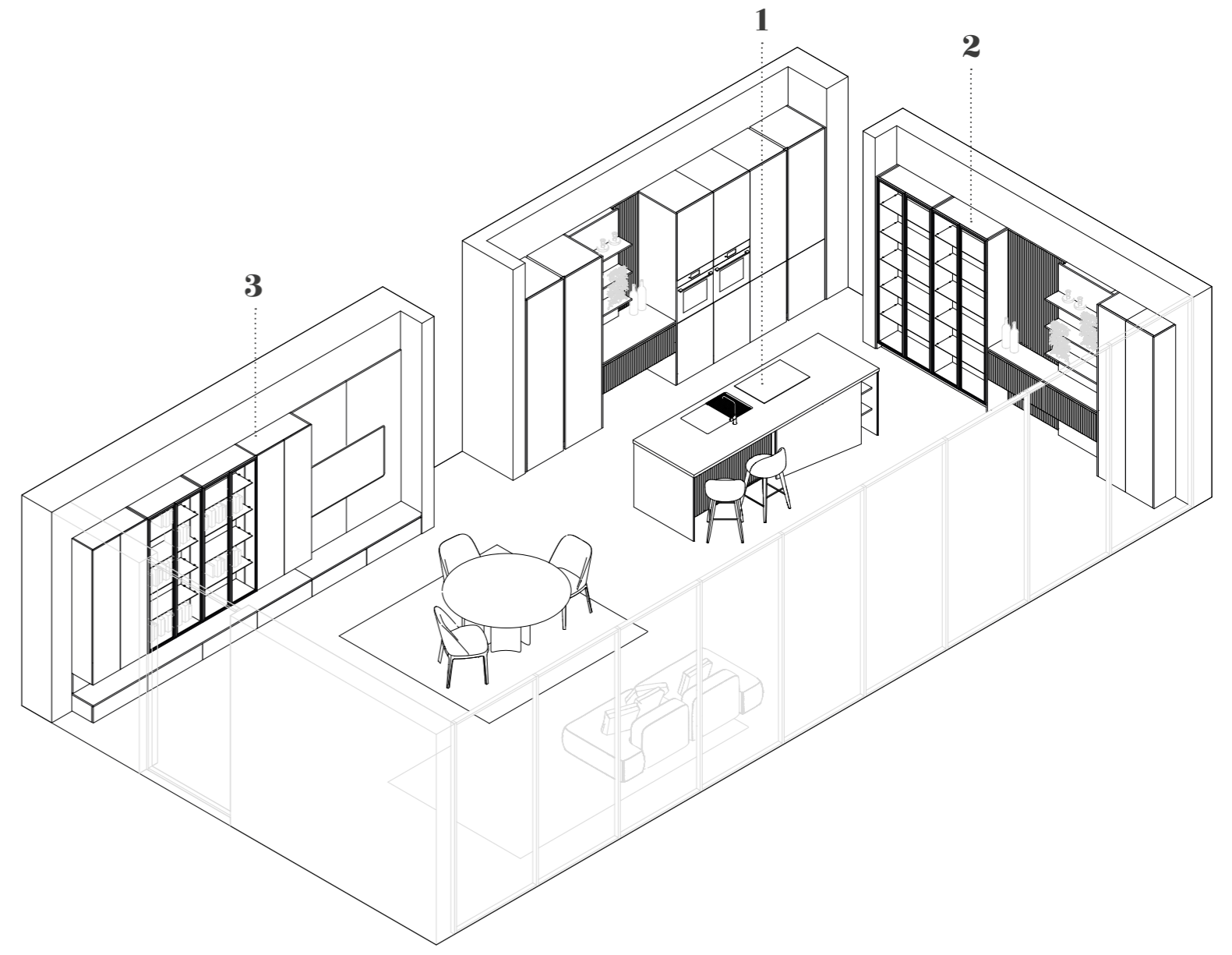

Geometrie Domestiche



Colonne H 235,5 (anta a terra + 9 cm)
 Basi gola H 81
 Pensili H 97,5
 Zoccolo H 10

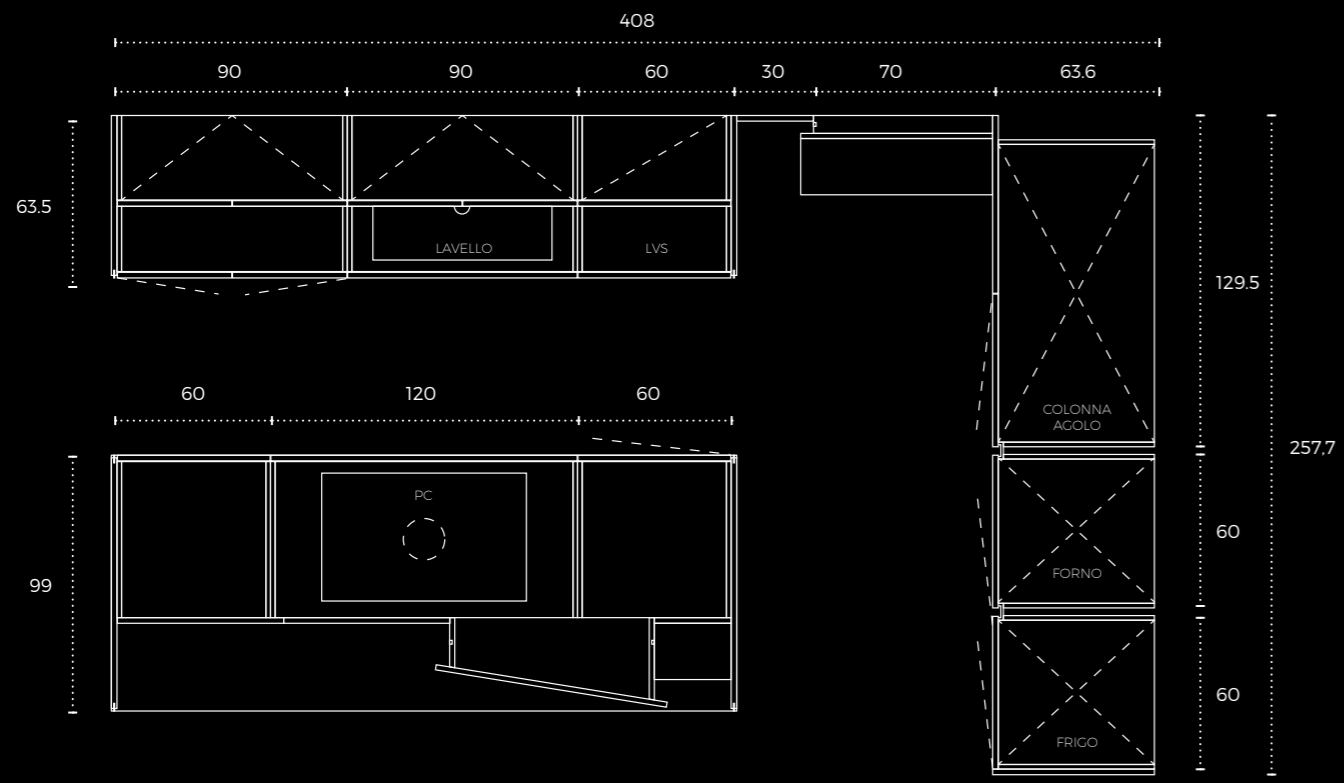

“Il jazz è la libertà di essere te stesso in un mondo che ti vuole uguale agli altri. È rabbia trasformata in ritmo, dolore che diventa eleganza.”

Cit. Charles Mingus



FLAT COSMIC 4th STORY

Una composizione che interpreta l'abitare contemporaneo come sintesi tra funzione e forma. La penisola, centro narrativo in laccato opaco Cosmic, è un elemento scultoreo dalle linee essenziali metallescenti, che unisce tecnologia e ricercatezza. La libreria integrata in Rovere nero, con dettagli bronzo, diventa segno di continuità tra cucina e living, estendendo la funzionalità in un gesto architettonico coerente e leggero. Il tavolo, dal profilo irregolare, si inserisce armoniosamente nella composizione, creando dinamismo e convivialità. Le colonne in finitura Rovere Nero custodiscono la zona tecnica e disegnano un ritmo fatto di pieni e vuoti, luce e ombra. I pensili, alti e rigati, completano il dialogo tra volumi orizzontali e verticali. In questo accordo impeccabile, la cucina si rivela come spazio fluido, capace di coniugare estetica, comfort ed identità.

A composition that interprets contemporary living as a synthesis of function and form. The peninsula, narrative center in matte Cosmic lacquer, is a sculptural element with essential metallic lines, combining technology and refinement. The integrated bookshelf in Rovere Nero, with bronze details, becomes a sign of continuity between kitchen and living, extending functionality in a coherent and light architectural gesture. The table, with an irregular profile, fits harmoniously into the composition, creating dynamism and conviviality. The columns in Rovere Nero finish contain the technical area and define a rhythm of solids and voids, light and shadow. The tall, ribbed wall cabinets complete the dialogue between horizontal and vertical volumes. In this impeccable accord, the kitchen reveals itself as a fluid space, able to combine aesthetics, comfort, and identity.







La parte operativa della cucina è abbracciata da fianchi a sormonto in laccato metallico Cosmic e piano di lavoro in gres Taj Mahal opaco, spessore 60 mm. Le ante, in laccato metallico Cosmic, sono dotate di maniglia a ponte in finitura nero opaco. I pensili rigati Tempo nella stessa finitura proseguono con la mensola Tune ad alto spessore in bilaminato Rovere Nero, completata da illuminazione LED sottostante.

The kitchen's working area is framed by overlapping side panels in metallic lacquered Cosmic and a matt Taj Mahal gres worktop, 60 mm thick. The Cosmic metallic lacquered doors with a bridge handle in matt black finish. Ribbed Tempo wall units in the same finish are continued by the thick Tune shelf in Rovere Nero bilaminated with integrated LED lighting underneath.



Fourth story. Flat Cosmic





Modulo a giorno Misty in bilaminato Rovere Nero con inserto Bronzo, ripreso anche nel colonnato con modulo a giorno alto, realizzato in laccato metallico Cosmic. Colonnato tecnico Flat in bilaminato Rovere Nero con maniglia a ponte e zoccolo in finitura nero opaco.

Misty open space in bilaminated Rovere Nero with Bronzo insert, echoed also in the tall open module within the column, made in Cosmic metallic lacquer. Flat technical column in bilaminated Rovere Nero with bridge handle and plinth in matte black finish.



Piano tavolo dalla forma ricercata in bilaminato Rovere Nero, appoggiato su moduli a giorno Misty che abbracciano la penisola operativa. La parete living è caratterizzata da boiserie sporgenti e mensole in bilaminato Rovere Nero con illuminazione LED verticale. In centro, incorniciano una boiserie rigata Tempo in laccato metallico Cosmic. Bussolotti a terra nella stessa finitura, ma con superficie liscia, completano la composizione.

The table top, with its refined shape in Rovere Nero bilaminated, rests on Misty open modules that embrace the functional kitchen peninsula. The living wall with projecting boiserie and shelves in Rovere Nero bilaminated with vertical LED lighting. In the middle Tempo boiserie in metallic lacquered Cosmic. Lower units in the same finish, but with a smooth surface, complete the composition.



Technical data

1

FLAT LACCATO METALLICO COSMIC
 FLAT LACCATO METALLICO COSMIC TEMPO
 FLAT BILAMINATO LEGNO ROVERE NERO
 WORKTOP GRES TAJ MAHAL OPACO SP 6 CM
 GOLA E ZOCCOLO NERO OPACO

Dimensione totale penisola H 265 L 490 cm
 Basi H 78 cm, Zoccolo H 10 cm
 Pensili H 117 cm
 Worktop sp. 6 cm
 Piano tavolo sp. 3 cm

2

FLAT BILAMINATO LEGNO ROVERE NERO
 INSERTI IN ALLUMINIO BRONZO

Dimensione totale colonne H 265 L 289 cm
 Colonne H 216 cm, sopra colonna H 39 cm Zoccolo H 10 cm
 Modulo a giorno Misty H 216 L 30 cm

3

LACCATO METALLICO COSMIC
 LACCATO METALLICO COSMIC TEMPO
 BILAMINATO LEGNO ROVERE NERO

Dimensione totale Living H 265 L 450 cm
 Basi a terra H 48 cm
 Boiserie H 265 cm

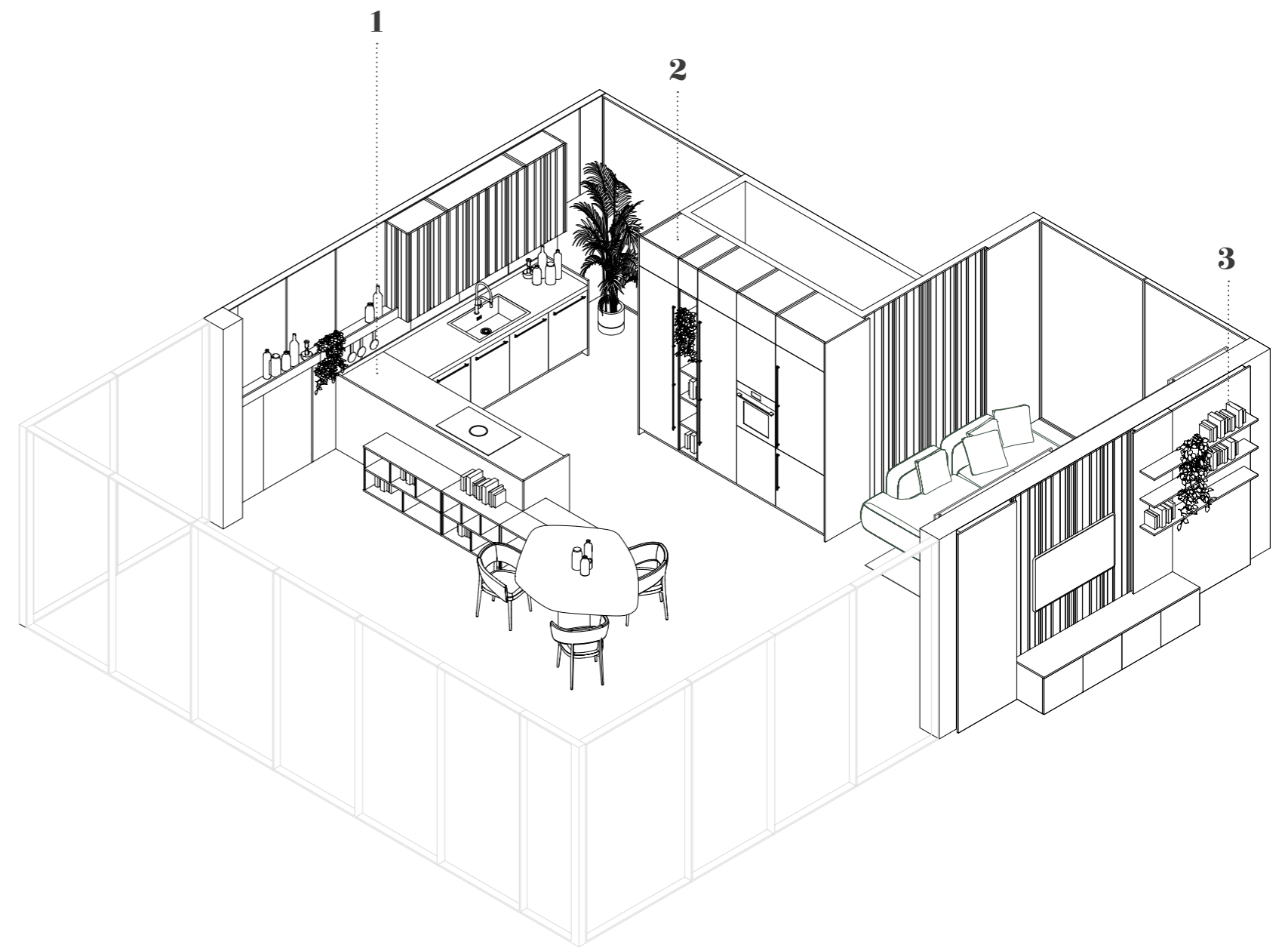

Geometrie Domestiche



FLAT LACCATO METALLICO COSMIC
 FLAT BILAMINATO LEGNO ROVERE NERO
 WORKTOP CRES TAJ MAHAL OPACO SP 1.2 CM
 INSERTI IN ALLUMINIO BRONZO

Colonne H 216 cm, sopracolonna H 39 cm
 Basi gola H 81
 Zoccolo H 10

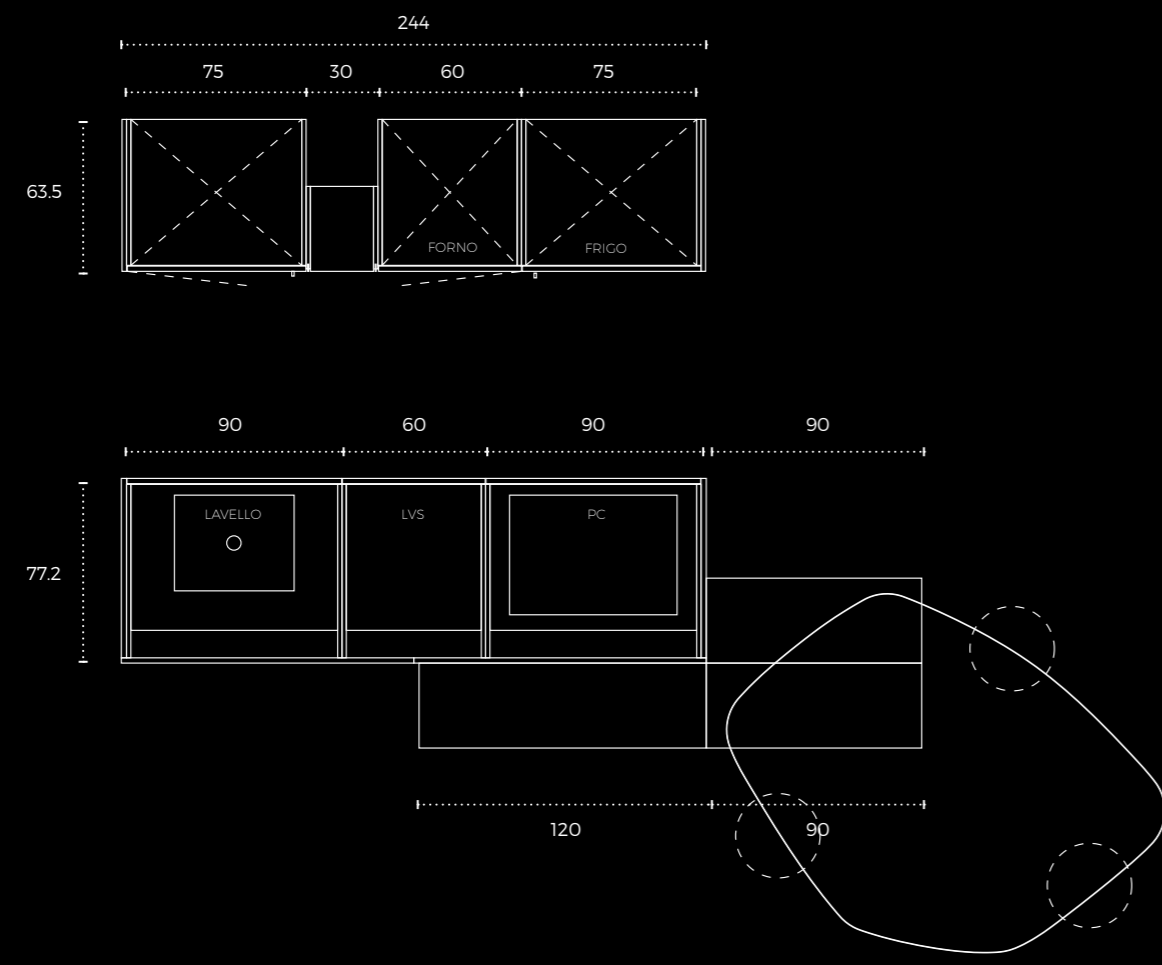

“Ogni volta che suono cerco di capire chi sono. Il sax mi risponde, ma non sempre con parole che voglio sentire.”

Cit. Sonny Rollins

FLAT DEEP HAVANA ⁵th STORY

Tra suggestioni d'altri tempi e spirito artigianale, la composizione trova nell'isola centrale il suo cuore espressivo. Lo stesso laccato opaco, Deep Havana, declinato nella finitura liscia e Always, crea un dialogo tra superfici che riflettono la luce in modo dinamico e misurato. Dietro, il sistema di colonne in Rovere Japan, integra la zona lavaggio e la nasconde, con un meccanismo vetrato, trasformando la parete in un volume continuo e ordinato, in cui funzione e design si fondono in un gesto fluido. Il piano in gres, con le sue venature vive, dialoga con i profili dorati e con il pavimento in terrazzo, in un equilibrio di richiami materici e cromatici. In questa armonia di trasparenze e proporzioni, la cucina si racconta come spazio elegante e contemporaneo, capace di evocare la memoria del fare artigianale e di interpretarla con linguaggio moderno.

Between timeless charm and artisanal spirit, the composition finds its expressive core in the central island. The same Deep Havana matt lacquer, offered in both smooth and ribbed Always finishes, creates a dialogue of surfaces that reflect light in a dynamic yet balanced way. Behind, the column system in Rovere Japan, integrates the washing area and conceals it with a glass-fronted mechanism, transforming the wall into a continuous and orderly volume, where function and design merge in a fluid gesture. The gres countertop, with its vibrant veining, interacts with the golden profiles and the terrazzo flooring, in a balance of tactile and chromatic echoes. In this harmony of transparencies and proportions, the kitchen reveals itself as an elegant, contemporary space — one that evokes the memory of craftsmanship while reinterpreting it through a modern design language.

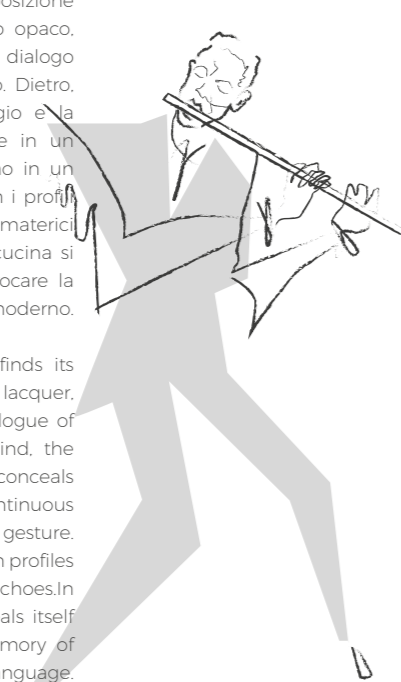

Kitchens in Jazz



Fifth story, Flat Deep Havana





Colonnato tecnico Flat in bilaminato Rovere Japan, completato dal sistema Wide for Kitchen con vetrine Evans in alluminio Bronzo e vetro Bronzo, dotate di apertura a pacchetto. Le basi interne, con zona lavaggio, e i pensili a tutta altezza sono realizzati in laccato opaco Visone nelle varianti liscia e rigata Always. Piano di lavoro e schienale in gres Tundra opaco, spessore 12 mm.

Technical Flat columns in Rovere Japan bilaminated, alternated with the Wide for Kitchen system featuring Evans glass doors in Bronze aluminum and Bronze glass with folding opening. The internal units, including the washing area and the tall wall units are made of matt lacquered Visone in both smooth and ribbed Always finishes. Worktop and backsplash in matt Tundra gres, 12 mm thick.







Particolare dell'isola con cassetti rigati Always in laccato opaco Deep Havana che proseguono lungo tutto il perimetro. Le ante inferiori sono anch'esse in laccato opaco Deep Havana. Piano di lavoro in gres Tundra opaco, spessore 12 mm. Accanto, mensola Tune in bilaminato Rovere Japan con illuminazione LED sottostante.

Detail of the island featuring Always ribbed drawers in matt lacquered Deep Havana, extending along the entire perimeter. The lower doors are also in matt lacquered Deep Havana. Worktop in Tundra matt gres, 12 mm thick. Next to it, Tune shelf in Rovere Japan bilaminate with integrated LED lighting underneath.



Vetrine Evans Air sospese in alluminio Bronzo e vetro Bronzo, installate su boiserie rigata Always in laccato opaco Visone, incorniciate da boiserie sporgenti con illuminazione LED verticale in bilaminato Rovere Japan. Tavolo Elis con piano in vetro Bronzo e gamba in Rovere TC rigato.

Suspended Evans Air glass units in Bronze aluminum and Bronze glass, mounted on Always ribbed boiserie in matt lacquered Visone, framed by projecting boiserie panels with vertical LED lighting in Rovere Japan bilaminate. Elis table with Bronze glass top and grooved Rovere TC wooden leg.

Technical data

1



FLAT
LACCATO
OPACO
DEEP HAVANA

FLAT
BILAMINATO
LEGNO
ROVERE JAPAN

EVANS AIR
ALLUMINIO
BRONZO
VETRO FUMÈ

FLAT
LACCATO
OPACO
VISONÈ

WORKTOP GRES
TUNDRA OPACO
12 MM

Dimensione totale colonne H 265 L 491,2 cm
Colonne H 216 cm, Sopracolonna H 39 cm
Zoccolo H 10 cm
Basi H 81 cm, Pensili H 117cm
Sistema Wide H 265 L 189,4 cm
Dimensione totale isola H 92,2 L 274,4

Dimensione totale libreria Sky 8 H 275 L 287 cm
Basi sospese H 39 L 90 cm

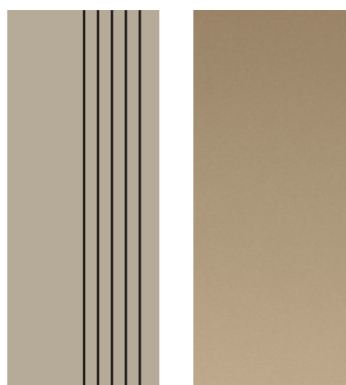

LACCATO
OPACO
VISONÈ

PALO
ALLUMINIO
BRONZO

2

3



LACCATO
OPACO
VISONÈ

BILAMINATO
LEGNO
ROVERE JAPAN

EVANS AIR
ALLUMINIO
BRONZO
VETRO FUMÈ

LEGNO
IMPIALLACCIATO
ROVERE TC

PIANO
VETRO
TRASPARENTE
FUMÈ

Dimensione totale Living H 275 L 470 cm
Vetrine H 138 cm
Tavolo Elis D 150 cm

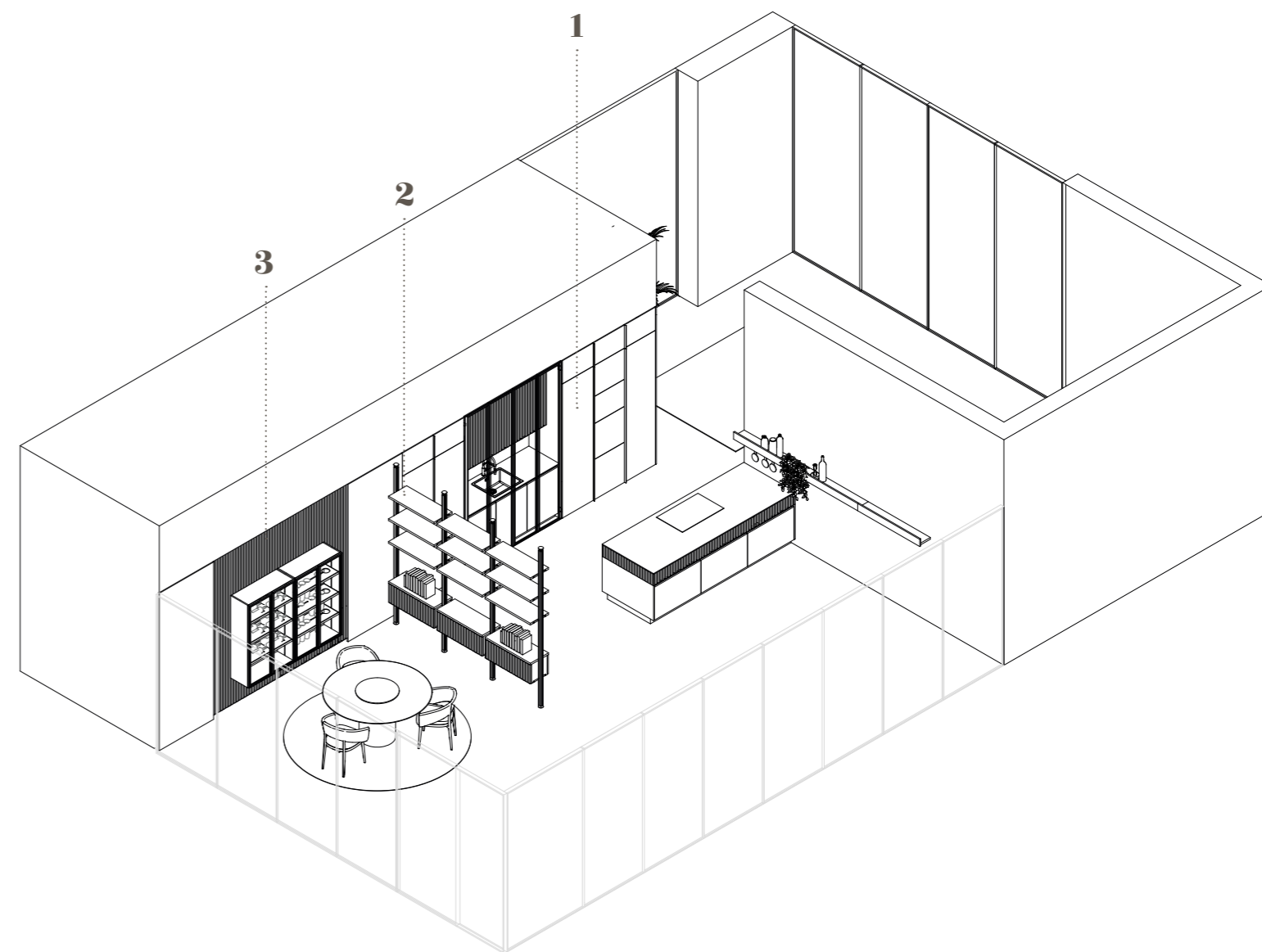

Geometrie Domestiche



Colonne H 235,5
 Basi gola H 81
 Pensili H 97,5
 Zoccolo H 10

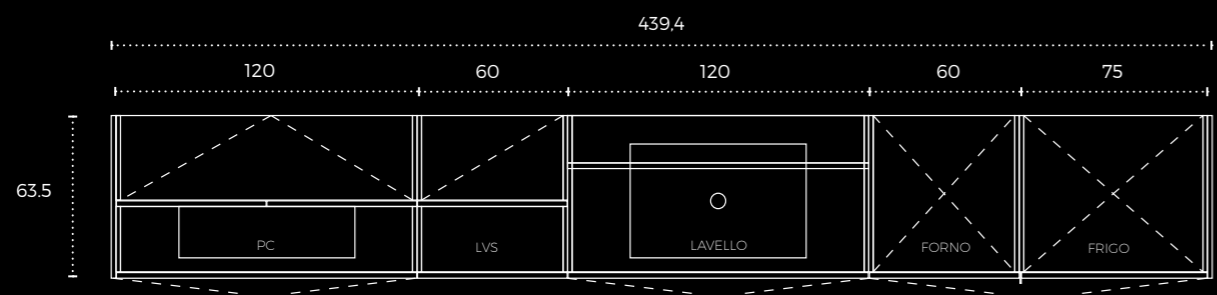

“Quando il jazz funziona, senti il tempo che si scioglie. È come ridere nel mezzo di una tempesta.”

Cit. Dizzy Gillespie

6th STORY

FLAT SAHARA BG

Tra memoria e contemporaneità: materiali pregiati, forme morbide e contrasti di volumi caratterizzano questa composizione dove il marmo Verde Borgogna diventa segno distintivo di carattere. L'isola, con il suo piano stondato che richiama le morbidezze del design retrò, è il fulcro visivo e tattile dell'ambiente: sensualità metallica e materia viva che uniscono presente e passato. Il tavolo circolare con gamba in vetro fumé introduce leggerezza e trasparenza, creando continuità tra zona operativa e conviviale. A parete, una differenza volumetrica tra basi e colonne, genera un dinamismo elegante che viene esaltato dal contrasto materico. Le vetrine, illuminate e accessoriate, arricchiscono il tutto di dettagli funzionali e preziosi. Definita da proporzioni misurate ed elementi autentici, la cucina interpreta il gesto quotidiano coniugando sapienza artigianale e linguaggio moderno.

Between memory and modernity, fine materials, soft forms and contrasts of volumes define this composition where Verde Borgogna marble becomes a distinctive sign of character. The island, with its rounded surface recalling the softness of retro design, is the visual and tactile fulcrum of space: metallic sensuality and living material that joins present and past. The circular table with smoked-glass leg introduces lightness and transparency, creating continuity between working and convivial zone. On the wall, a volumetric difference between bases and columns creates an elegant dynamism enhanced by the material contrast. Glass units, illuminated and equipped, enrich the whole with functional and refined details. Defined by measured proportions and authentic elements, the kitchen interprets the daily gesture combining artisanal skill and modern language.

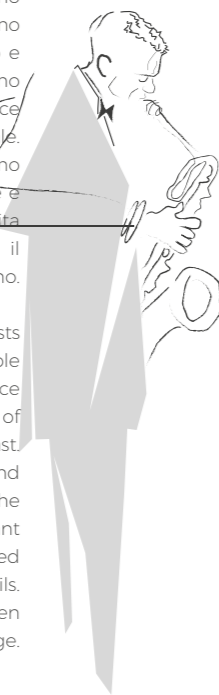





Le colonne Flat in bilaminato Mandorlo sono affiancate da vetrine attrezzate Evans Air in alluminio Bronzo e vetro Bronzo, dotate di cassetti sospesi rivestiti in eco-pelle Bufalo beige e ripiani in alluminio Nero con portacalici e portabottiglie integrati. Il dettaglio arrotondato del top in Marmo Verde Borgogna riprende la curvatura del fianco dell'isola, realizzato in laccato metallizzato Brunito.

The Flat columns in Mandorlo bilaminated is flanked by Evans Air glass units in Bronze aluminum and Bronze glass, featuring suspended drawers upholstered in Bufalo beige eco-leather and Black aluminum shelves equipped with glass holders and bottle racks. The rounded detail of the countertop in Verde Borgogna marble echoes the curved shape of the island side panel in brushed metallic Brunito lacquer finish.



Sixth story. Flat Sahara BG





Il piano circolare in bilaminato Mandorlo del tavolo abbraccia e riprende la linea curva del fianco dell'isola Flat, realizzata in laccato metallizzato Brunito e completata da un top con bordo speciale curvo in Marmo Verde Borgogna lucido. Sul fondo, il sistema divisorio Modwall in bilaminato Mandorlo con telaio in finitura Bronzo integra due porte a bilico, creando una separazione elegante tra due ambienti domestici.

The round shape table in Mandorlo bilaminated embraces and echoes the curved side of the Flat island in Brunito metallic lacquer finish with a special curved-edge countertop in polished Verde Borgogna marble. In the background, the Modwall dividing system in bilaminated Mandorlo with a Bronzo frame features two pivot doors, elegantly separating the two living spaces.



Sixth story. Flat Sahara BG



Particolare dell'isola Flat con fianchi curvi in laccato metallizzato Brunito, gola e zoccolo in finitura Bronzo.

Detail of the Flat island featuring curved side panels in Brunito metallic lacquer, with groove handle and plinth in Bronze finish.



Alla stanza dispensa si accede tramite una porta filo muro in laccato opaco Sahara BG, coordinata con la finitura della cucina. Le basi Flat della dispensa, con apertura a gola in Super Matt Green EX e piano top in laminato, dialogano armoniosamente con la struttura alta in bilaminato Mandorlo, arricchita da illuminazione LED verticale integrata.

Access to the pantry room is through a flush-to-wall door in matte Sahara BG lacquer, matching the kitchen finish. The Flat base units of the pantry, with a groove opening in Super Matt Green EX and a laminate countertop, blend seamlessly with the tall structure in Mandorlo bilaminate, enhanced by integrated vertical LED lighting.



Sixth story. Flat Sahara BG

Technical data

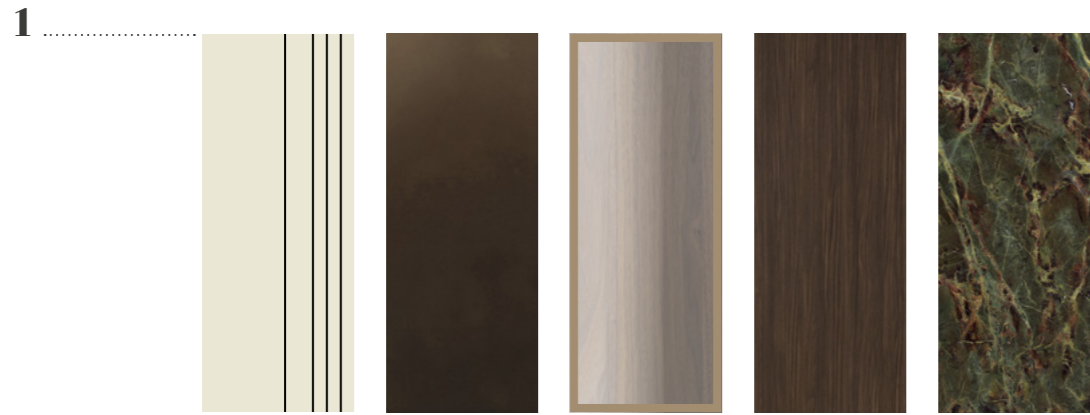

LACCATO OPACO SAHARA BG
 LACCATO METAL BRUNITO
 EVANS AIR ALLUMINIO BRONZO VETRO BRONZO
 BILAMINATO LEGNO MANDORLO
 WORKTOP MARMO VERDE BORGOGNA SP. 3CM

Dimensione totale lineare H 245.5 L 490 cm
 Colonne H 235.5 cm, Zoccolo H 10 cm
 Dimensione total colonne H 245.5 L 429.6 cm
 Basi H 81, Pensili H 58.5 cm
 Dimensione totale isola H 92.2 L 350 cm
 Isola H 92.2 L 246 cm

Dimensione totale H 259.5 L 240 cm
 Basi gola H 81
 Libreria dispensa H 259.5 L 287 cm

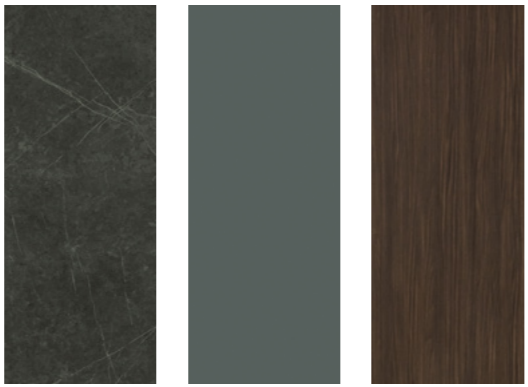

WORKTOP LAMINATO MARMO GUATEMALA SP. 4CM
 SUPER MATT ECCIMERI GREEN EX
 BILAMINATO LEGNO MANDORLO

2

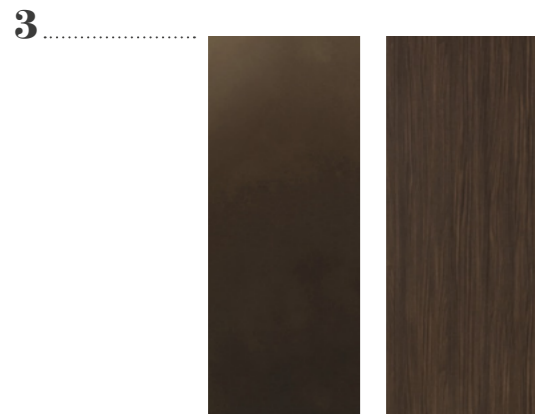

LACCATO METAL BRUNITO
 BILAMINATO LEGNO MANDORLO

Dimensione totale Living H 270 L 240 cm
 Basi sospese H 39 cm
 Modwall H 270 cm

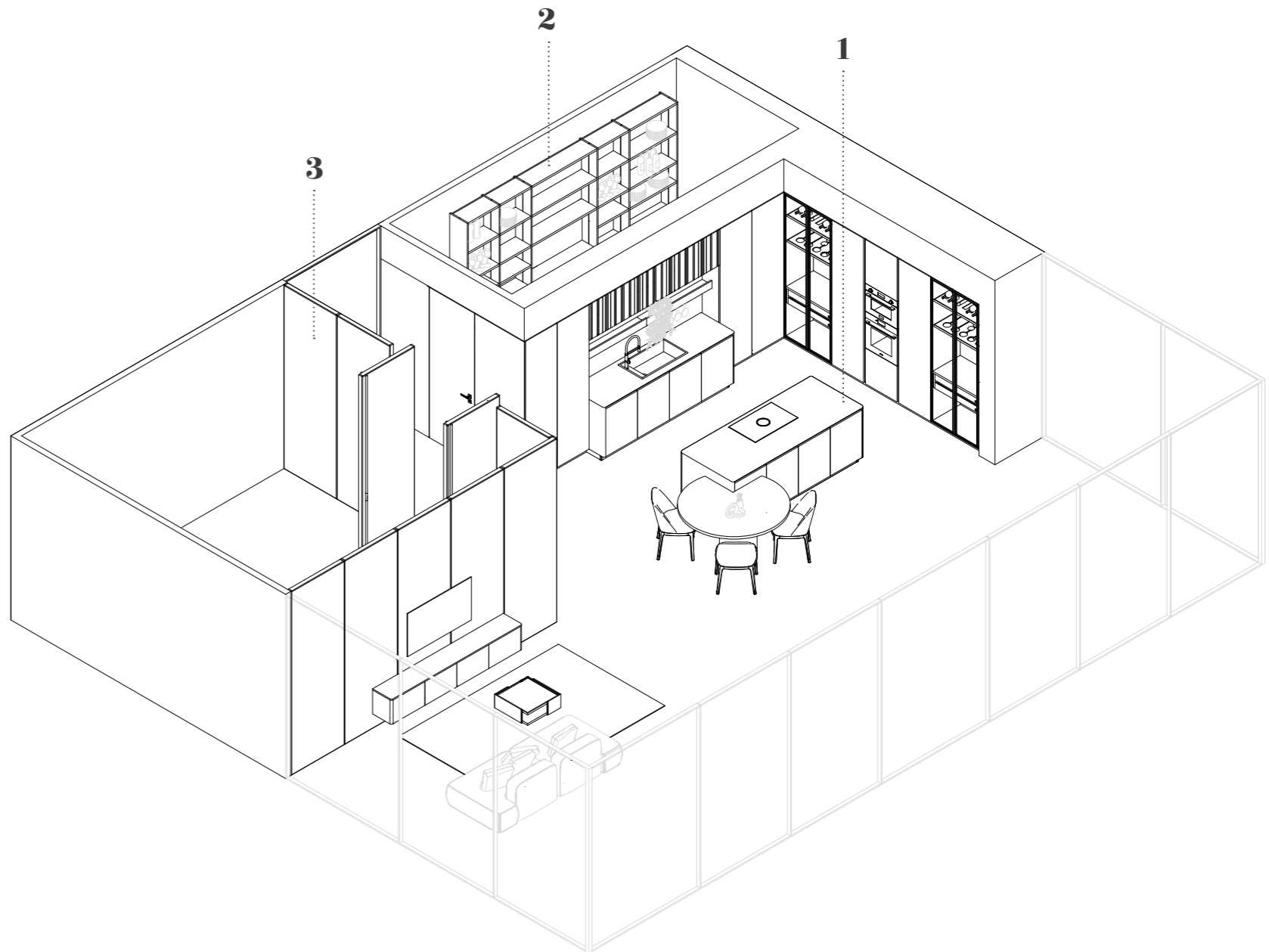

Geometrie Domestiche

FINITURE COMPOSIZIONE

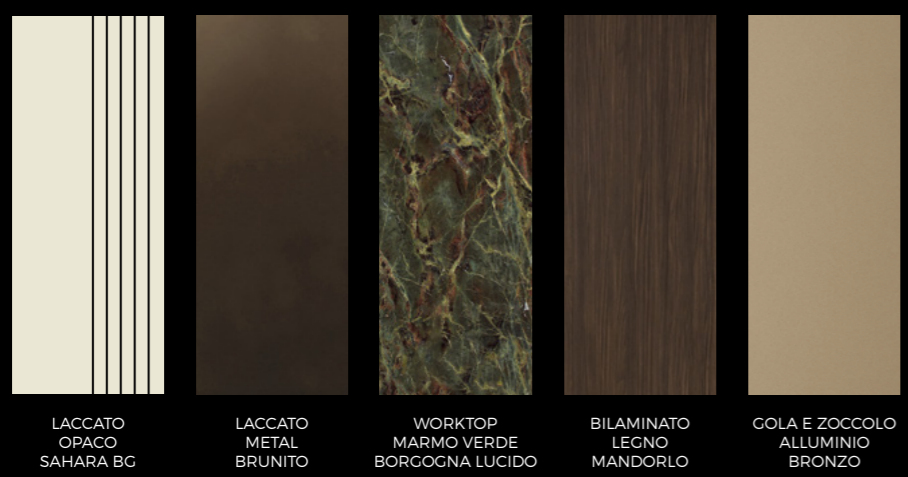

Colonne H 235.5
Basi gola H 81
Zoccolo H 10

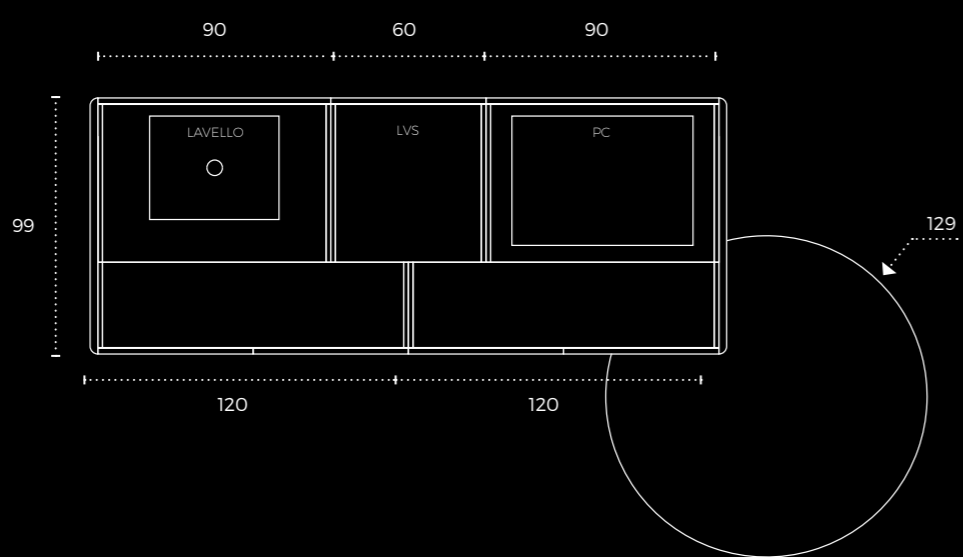
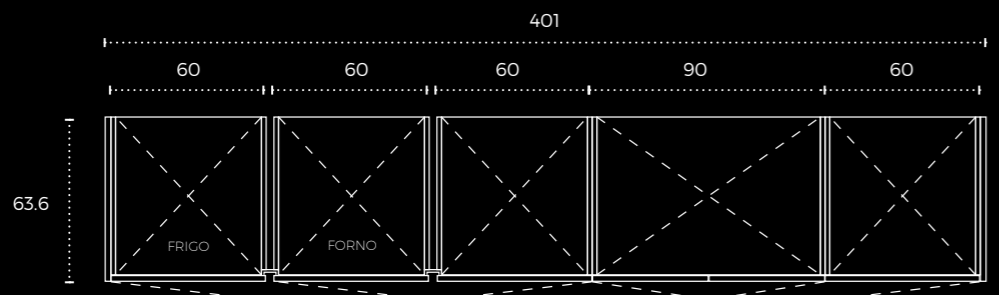

“Il jazz non è uno stile. È un modo di stare al mondo. Devi essere rilassato ma sveglio, dolce ma deciso. Se suoni teso, menti. E il pubblico se ne accorge.”

Cit. Lester Young

SKINNY ROVERE CLOUD

7th STORY

Un open space in cui luce materiali e geometrie si fondono in una sensazione di profonda serenità ed equilibrio. Superfici materiche e volumi essenziali dialogano con naturalezza, mentre il gres effetto pietra Mountain Pick, intenso e strutturato, conferisce carattere e identità all'ambiente. Il telaio sottile del modello Skinny, in finitura laccata e in essenza, si declina come segno grafico discreto ed elegante sia nell'isola che nelle colonne, definendo con precisione i volumi. L'isola centrale, fulcro visivo e spaziale, si distingue per il particolare gioco delle ante, perfettamente bilanciato tra presenza scenica e leggerezza percettiva. Le ampie vetrate aprono lo spazio verso l'esterno, lasciando fluire la luce naturale che valorizza materiali e volumi. Ne risulta uno spazio contemporaneo, pensato per un abitare autentico e senza tempo.

An open space where light, materials, and forms merge to create a sense of deep serenity and balance. Textured surfaces and essential volumes interact naturally, while the Mountain Pick stone-effect porcelain adds character and identity to the environment. The slim frame of the Skinny model, available in both lacquered and wood finishes, acts as a discreet and elegant graphic element, defining the volumes with precision in both the island and the cabinetry. The central island, the visual and spatial focal point, stands out for the unique rhythm of its doors, perfectly balanced between a strong presence and perceptual lightness. Large windows open the space to the outdoors, allowing natural light to flow in and enhance the materials and volumes. The result is a contemporary space designed for authentic, timeless living.



Kitchens in Jazz



Seventh story. Skinny Rovere cloud





Dettaglio dell'isola con worktop ad alto spessore in Mountain Peak e anta Skinny in impiallacciato Rovere Cloud. Skinny è un'anta telaio in legno di Rovere costituita da una cornice sottile assemblata a 45° di spessore frontale 1 cm.
Detail of the island featuring a thick Mountain Peak countertop and a Skinny door in Rovere Cloud veneer. Skinny is a solid oak frame door consisting of a slim 45-degree mitered frame with a 1-cm-thick front panel.



Composizione operativa a parete con basi e colonne Skinny in laccato opaco Grigio Mo caratterizzate da maniglia a ponte in finitura bronzo, orizzontale e verticale. Pensili H 117 Skinny in impiallacciato Rovere Cloud. Sulla sinistra, modulo a giorno Misty con inserti bronzo.

Worktop ad alto spessore H 6 in Mountain Peak con lavello sottotop. Isola centrale in impiallacciato Skinny Rovere Cloud, con gola intermedia e zoccolo in Grigio Mo. Worktop ad alto spessore anche sull'isola, che ospita il piano cottura.

Wall-mounted functional composition with Skinny base units and columns in lacquered matt Grigio Mo, featuring horizontal and vertical bridge handles in a Bronze finish. Skinny H 117 wall cabinets in Rovere Cloud veneer. On the left, open Misty module with bronze inserts. Thick 6 cm Mountain Peak worktop with undermount sink. Central island in Skinny Rovere Cloud veneer, with recessed groove and plinth in matt lacquered Grigio Mo. Thick worktop also on the island, accommodating the cooktop.





Sistema divisorio Modwall in Rovere Cloud con telaio in finitura Bronzo che integra una porta a bilico, creando un'elegante separazione tra due ambienti domestici con un design raffinato e moderno. Dettaglio della maniglia tubolare in bronzo con presa in ecopelle chiara.

Modwall partition system in Rovere Cloud with a Bronze-finish frame, featuring a pivot door that creates an elegant separation between two living spaces with a refined and modern design. Detail of the tubular Bronze handle with a light eco-leather grip.





Parete living caratterizzata da bussolotti a terra in laccato opaco Grigio Mo e pensili alti nella stessa finitura. Sulla sinistra, pensili vetrina con ante Evans Air in alluminio Bronzo e vetro Fumè. Centralmente, libreria Misty in Rovere Japan con inserto bronzo, che ospita la zona televisione. Tavolo Yass circolare Ø 150 in Deep Havana.

Living wall featuring floor-standing units in lacquered matt Grigio Mo and tall wall cabinets in the same finish. On the left, display cabinets with Evans Air doors in Bronze aluminum and smoked glass. In the center, Misty bookshelf in Japan Oak with a bronze insert, housing the TV area. Yass round table Ø 150 in Deep Havana.

Technical data

1

LEGNO ROVERE CLOUD
 LACCATO OPACO GRIGIO MO
 BILAMINATO DARK FABRIC
 WORKTOP GRES MOUNTAIN PEAK LUCIDO SP. 6 CM

Dimensione totale lineare H 265 L 427 cm
 Colonne H 210 cm e sopracolonna H 39, Zoccolo H 10 cm
 Dimensione totale colonne H 265 L 433 cm
 Basi H 78 maniglia, Pensili H 117 cm
 Dimensione totale isola H 94 L 306 cm
 Basi H 78 gola centrale

2

Dimensione totale Living H 254 L 720 cm
 Basi gola H 24, Colonne H 192 cm
 Libreria H 192 L 225 cm

BILAMINATO OPACO GRIGIO MO
 BILAMINATO LEGNO ROVERE JAPAN
 EVANS AIR ALLUMINIO BRONZO VETRO BRONZO

3

BILAMINATO LEGNO ROVERE JAPAN
 ALLUMINIO BRONZO
 ECO-PELLE BEIGE

Dimensione totale Modwall H 270 L 300 cm

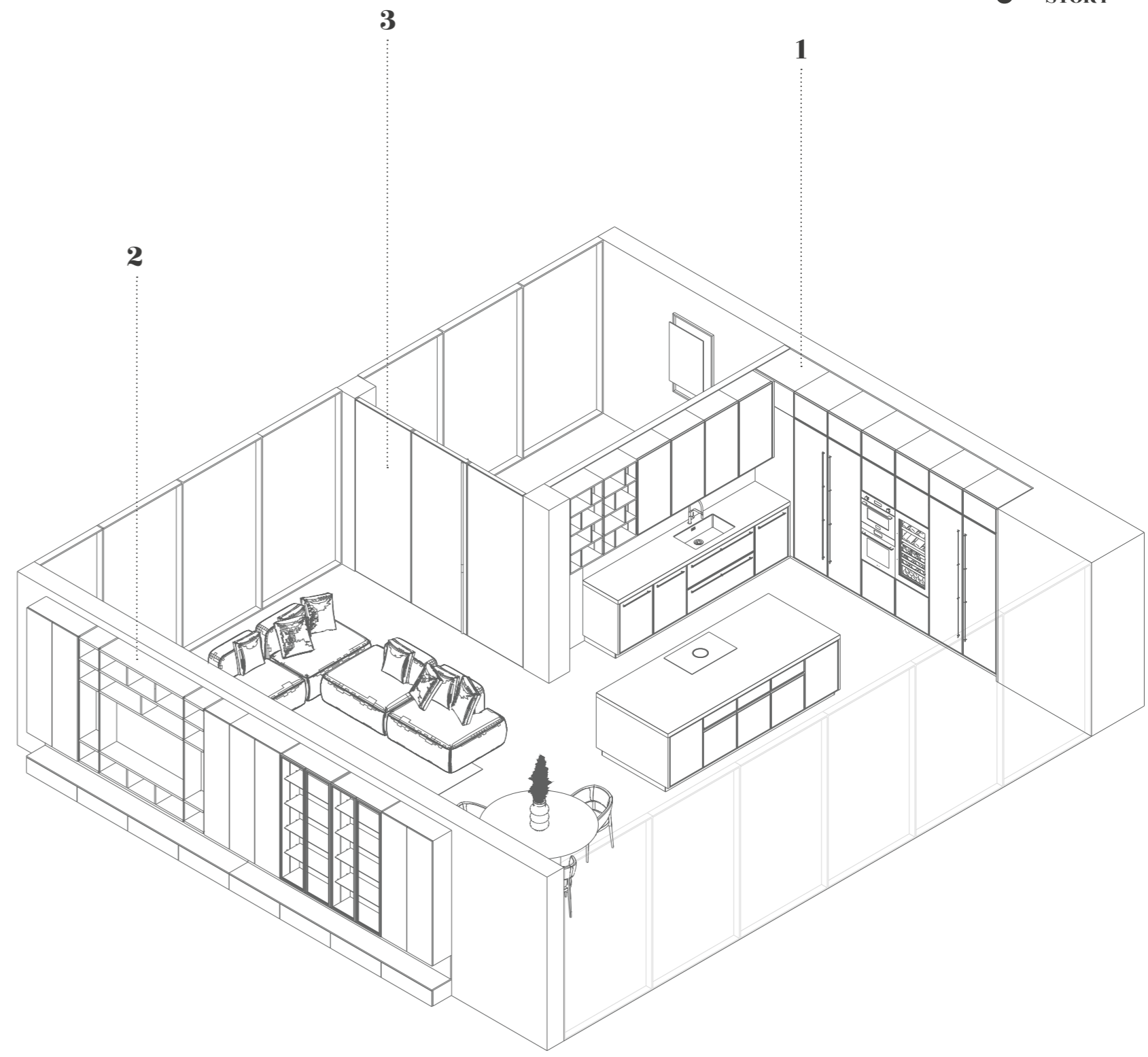

Geometrie Domestiche

FINITURE COMPOSIZIONE

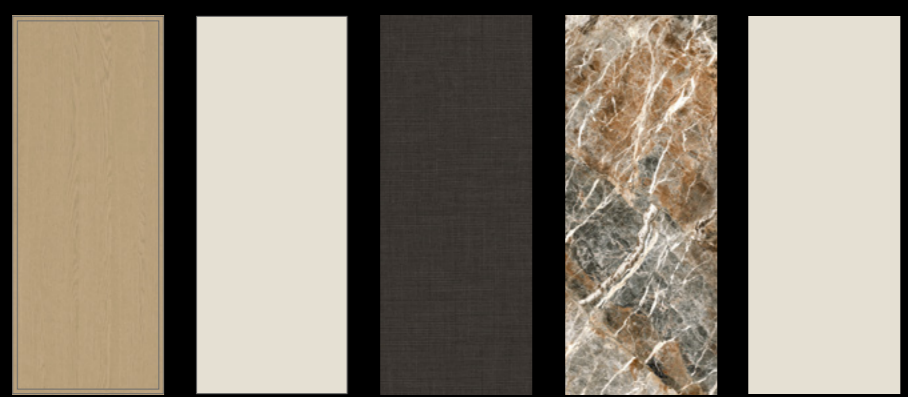

LEGNO ROVERE CLOUD
 LACCATO OPACO GRIGIO MO
 BILAMINATO DARK FABRIC
 WORKTOP GRES MOUNTAIN PEAK LUCIDO SP. 1,2 CM
 ZOCCOLO LACCATO OPACO GRIGIO MO

Colonne H 216+39
 Basi maniglia H 78
 Zoccolo H 10

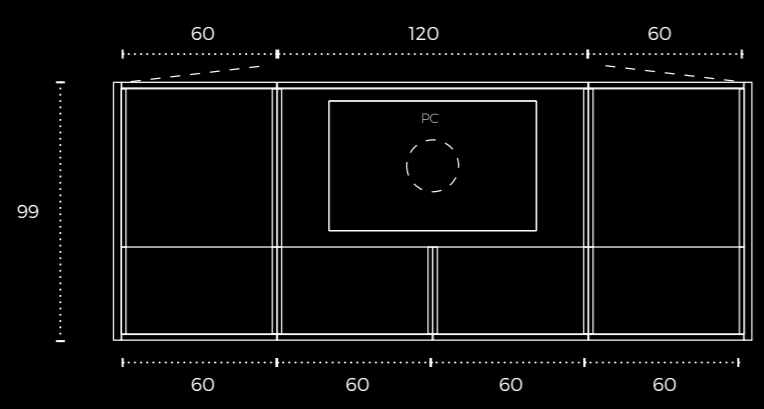
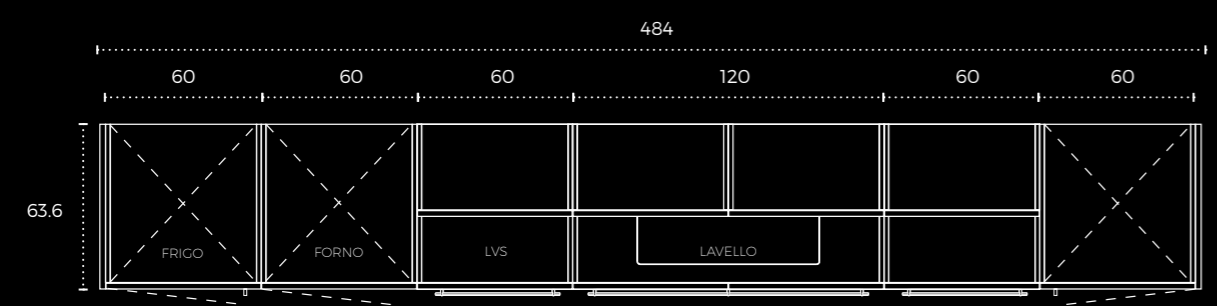

Elementi speciali



VETRINA SPECIALE

Colonna vetrina equipaggiata con ripiani porta bottiglie/calici costituiti da telaio in alluminio nero e piano in stratificato nero opaco. La base inferiore è caratterizzata da due frontali cassetto rivestiti in eco-pelle.

Glass column equipped with bottle/glass shelves consisting of black aluminium frame and matt black laminate top. The lower base features two drawer fronts covered in eco-leather.

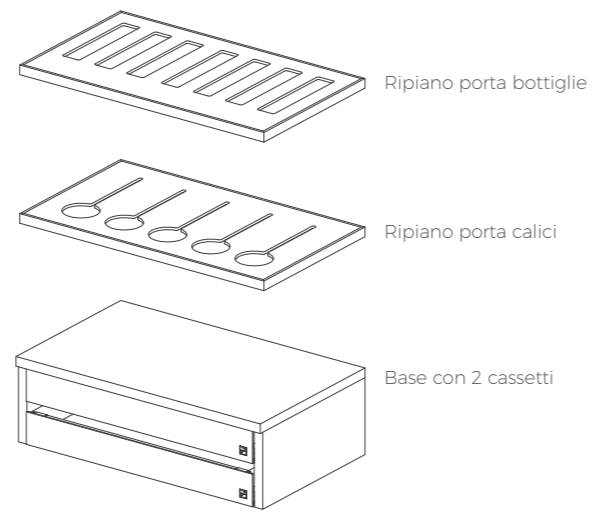

MODULI A GIORNO MISTY

Il sistema è caratterizzato da inserti in alluminio bronzo o nero posti sul bordo frontale di ciascun elemento verticale. Il fondo ed il cielo vincono sui fianchi in modo da consentire l'accostamento tra di essi.

The system features bronze or black aluminium inserts on the front edge of each vertical element. The bottom and top panels extend beyond the sides in order to allow matching between them.

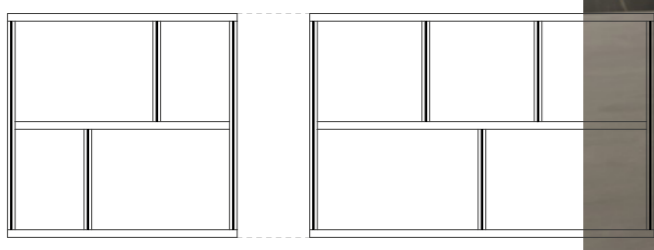

Kitchens in Jazz



RETRO-ISOLA WING

La sua particolare forma inclinata di 10° garantisce un solido piano snack ed evita i possibili imbarcamenti. Allo stesso tempo genera da un lato uno spazio contenitivo e dall'altro un'ampia area per le sedute.

Its unique 10° incline ensures a stable snack table and prevents possible bending. At the same time, it creates storage space on one side and a large seating area on the other.

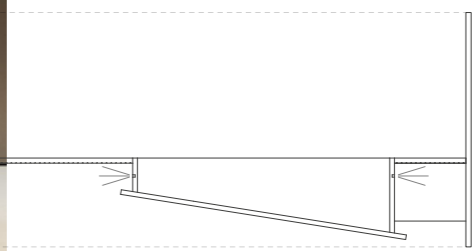

WIDE-K SYSTEM

Il sistema di ante a pacchetto Wide consente di nascondere un'area interna di 180 cm. Le ante si ripiegano sui vani adiacenti in modo da garantire il completo utilizzo della zona operativa.

The Wide folding door system allows you to hide an internal area of 180 cm. The doors fold over the adjacent compartments to ensure full use of the operating area.

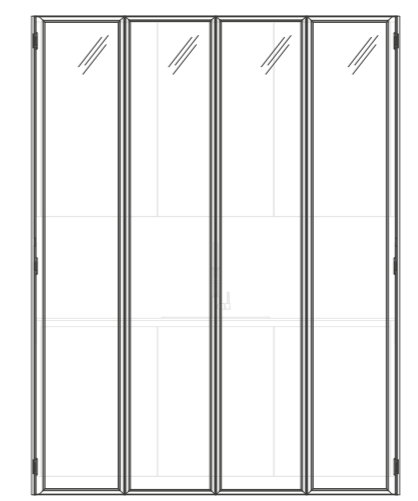
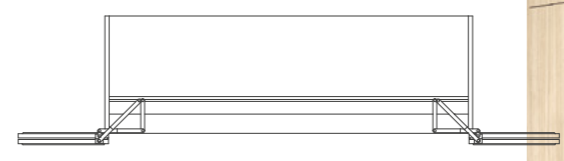

Special elements

Elementi speciali



MENSOLA TUNE

Mensola sp. 3 cm con frontale a T che crea un balconcino per trattenere gli oggetti e schermare la luce. Il profilo frontale alto 12 cm offre luce indiretta e uniforme, mantenendo un'estetica pulita e sobria.

3 cm thick shelf with T-shaped front edge that creates a small balcony to hold objects and shield the light. The 12 cm high front profile provides indirect, uniform lighting while maintaining a clean.

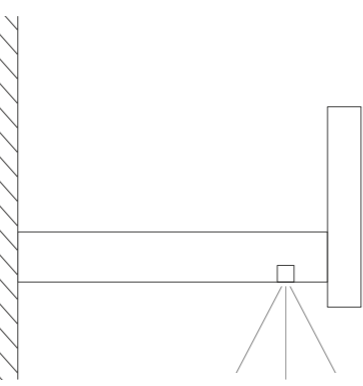

FIANCO CURVO

Il fianco curvo di sp. 3 cm stondato sui lati verticali, chiude la composizione con un segno fluido che ammorbidisce i volumi e dona continuità visiva all'insieme creando un elegante effetto molto avvolgente.

The curved side, 3 cm thick and rounded on the vertical sides, completes the composition with a fluid line that softens the volumes and gives visual continuity to the whole, creating an elegant effect.

R 3 cm

BOISERIE SPORGENTE

La composizione nasce per attenuare il ritmo regolare delle colonne, introducendo un pratico spazio operativo. La boiserie sporgente, arricchita da led verticale, crea un effetto luminoso morbido e suggestivo.

The composition is designed to break up the regular rhythm of the columns, introducing a practical workspace. The protruding boiserie, enhanced by vertical led lights, creates a soft and evocative effect.

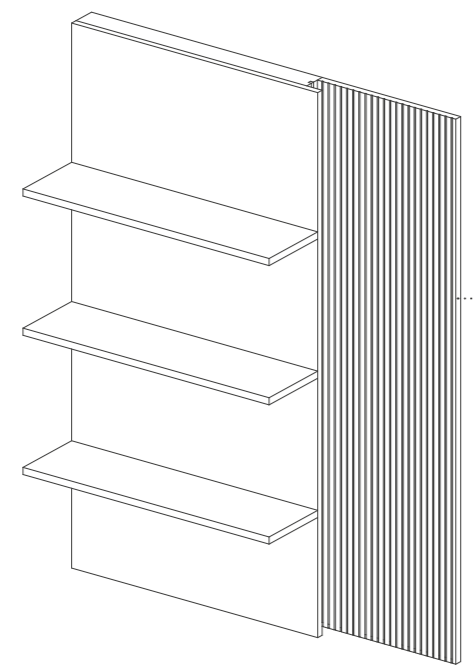

Kitchens in Jazz

FIANCO MISTY

Il fianco Misty integra inserti in alluminio bronzo o nero sul bordo frontale, che snelliscono lo spessore del pannello e aggiungono carattere e ricercatezza in ogni dettaglio, donando un segno distintivo in più.

The Misty side panel features bronze or black aluminium inserts on the front edge, which slim down the thickness of the panel and add character and refinement to the detail, giving it an extra distinctive touch.



Special elements

Elementi speciali



GAMBA MISTY

La gamba Misty è caratterizzata da un inserto in alluminio bronzo o nero sul bordo frontale, che arricchisce e snellisce lo spessore del pannello e può essere realizzata in varie finiture.

The Misty leg features a bronze or black aluminum insert on the front edge, which enriches and slims the thickness of the panel and can be made in various finishes.



COLONNA CANTINETTA

Colonna speciale che ospita cantinetta vini, ideale per chi cerca una soluzione di grandi dimensioni e di grande impatto scenico.

Special column that houses a wine cellar, ideal for those looking for a large solution with a great scenic impact.

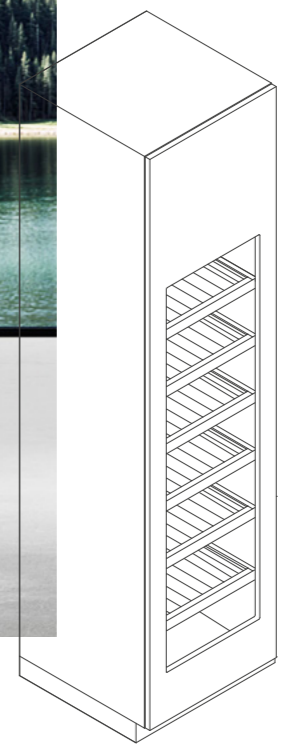

SKY 8 DISPENSA

Un sistema di pali con ancoraggio da terra a soffitto in grado di consentire sia divisione parziale tra gli ambienti che contenimento. Il suo nome deriva dalla sezione ottagonale del palo.

A system of poles anchored from the ground to the ceiling that can provide both partial partitioning and storage. Its name derives from the pole's octagonal cross-section.

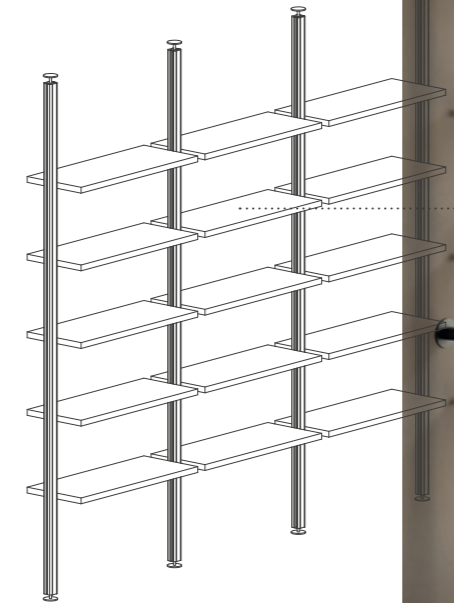

Kitchens in Jazz

VETRINE EVANS AIR

La vetrina Evans Air è un telaio in alluminio, disponibile in nero o bronzo, che racchiude un vetro di varie finiture. L'apertura è consentita mediante cerniere affogate sul fondo e sul cappello.

The Evans Air display case is an aluminium frame, available in black or bronze, which houses glass in a variety of finishes. It opens via concealed hinges at the bottom and top.



Special elements

Elementi speciali



GAMBA IN VETRO

Particolare gamba in vetro sp.10mm , realizzabile in vetro trasparente, fumè e bronzo. Una soluzione pensata per donare al progetto leggerezza visiva e trasparenza spaziale.

Detail of a leg made from 10mm-thick glass, available in clear, smoked and bronze finishes. A design intended to lend the project a sense of visual lightness and spatial transparency.



BASE SPECIALE CON CASSETTO

Base speciale con gola intermedia, caratterizzata da un cassetto superiore rigato e da un cestone inferiore liscio. Crea un raffinato gioco grafico tra le ante, valorizzando il ritmo compositivo del progetto.

A special base unit with a central recess, featuring a ribbed top drawer and a smooth bottom basket. It creates a sophisticated visual interplay between the doors, enhancing the design's compositional rhythm.

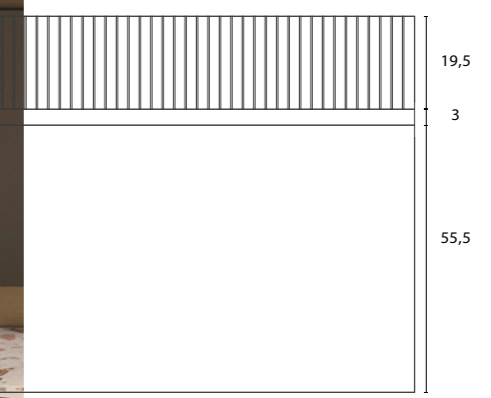

PIANO SASSO

Piano in laminato dalla forma irregolare disponibile in varie dimensioni e finiture. sp. 4 cm. Un elemento distintivo pensato per introdurre dinamismo e convivialità.

An irregularly shaped laminate worktop available in various sizes and finishes. 4 cm thick. A distinctive feature designed to bring dynamism and a sense of conviviality.



SKINNY

Skinny è un'anta telaio in legno di Rovere costituita da una cornice sottile assemblata a 45° di spessore frontale 1 cm.

Skinny is a frame door in oak wood made up of a thin frame assembled at 45° with a front thickness of 1 cm.

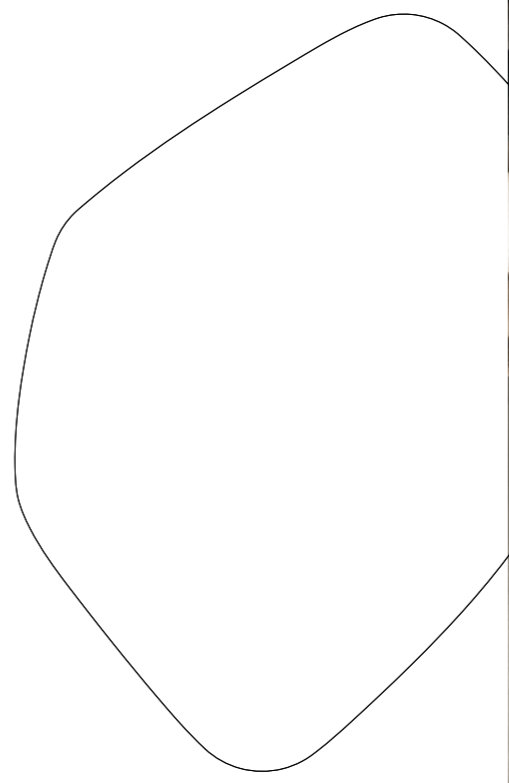
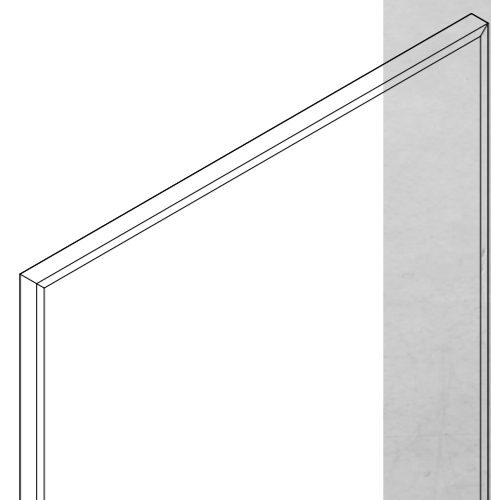

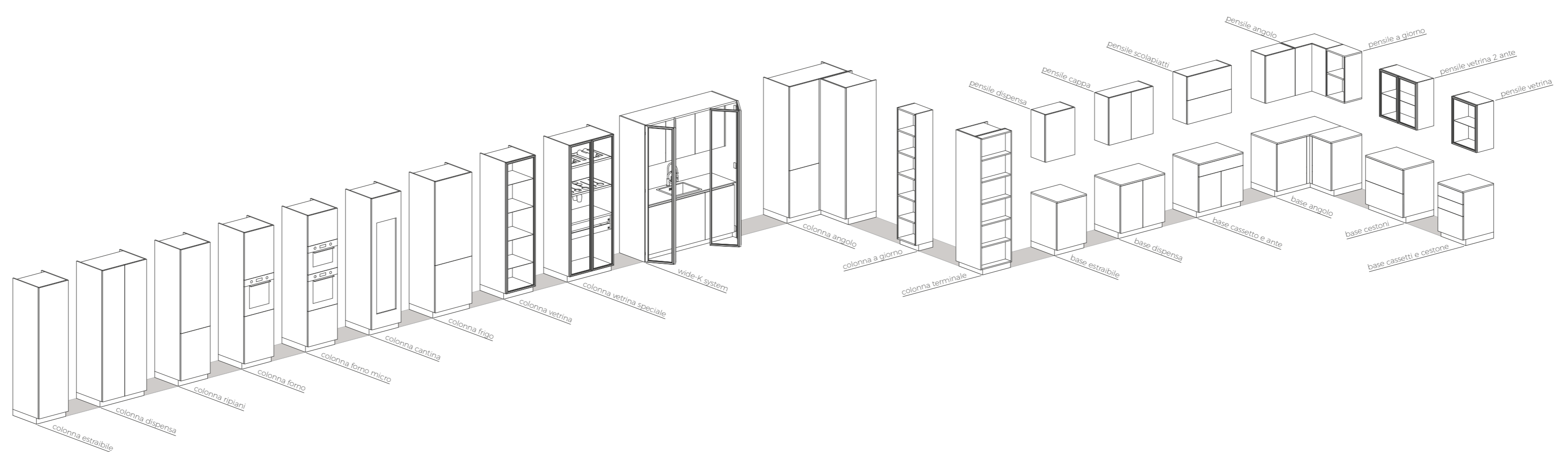

Ergonomia Maniglia - Handle

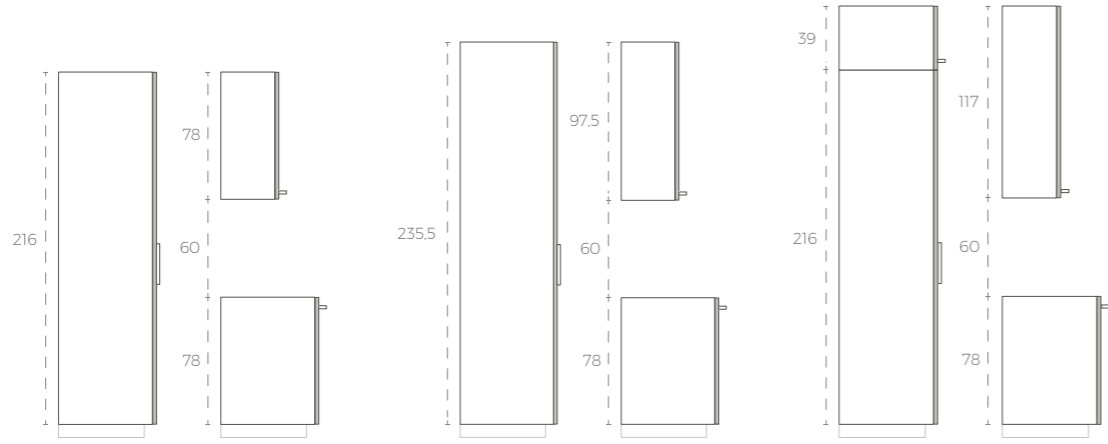

Ergonomia Gola - Groove

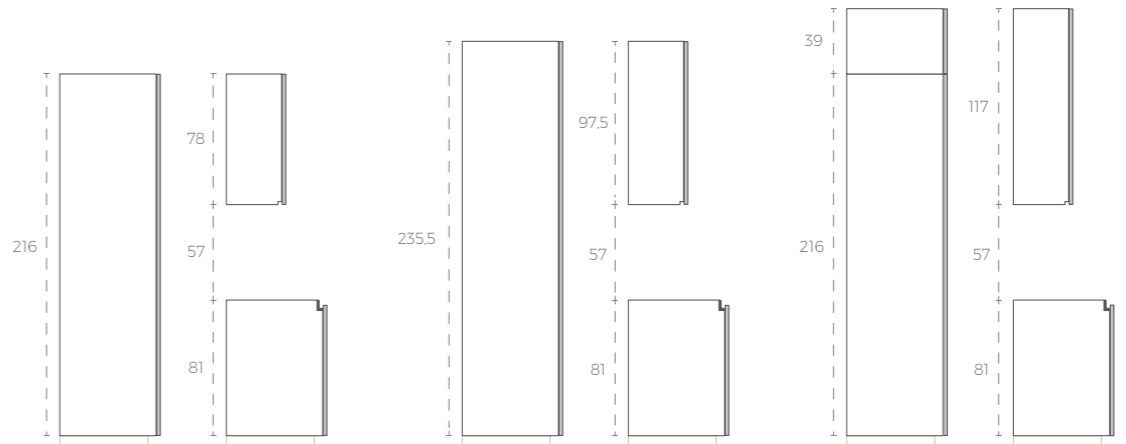

Art direction
Mama Studio

Graphic design
Mama Studio

Product design
Mama Studio
Giuseppe D'Ecclesia

Copy
Mama Studio

Render
Matic animation

Color separation
Francesca Di Giovanni

Print
Antezza

2026

GUZZINI & FONTANA PROJECTS S.R.L.
Via Grecia - Palazzese, Roseto degli Abruzzi
64026 (TE) Italy
Cod. Fisc. / P.IVA 01927160679
Tel. +39 085 8069006
info@guzziniefontana.it



The mark of
responsible forestry
FSC® C136814



Guzzini & Fontana project s.r.l. può apportare ai prodotti modifiche, migliorie tecniche, annullamenti di articoli di fine serie che siano ritenuti opportuni, in qualsiasi momento e senza alcun preavviso.
Guzzini & Fontana project s.r.l. reserves the right to modify its products, apply technical improvements or cancel end-of-series articles when deemed opportune and at any time, without prior notice.