

# LIVING IN JAZZ

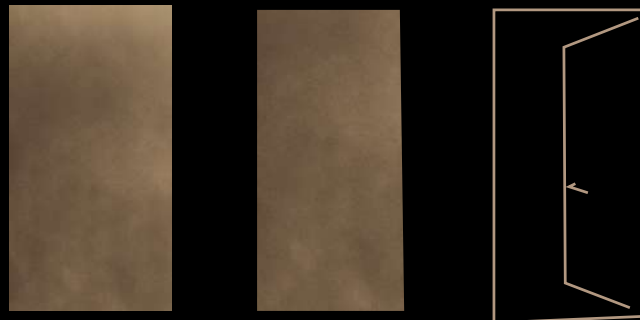

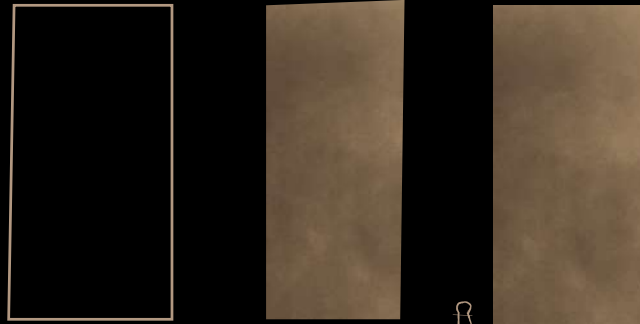
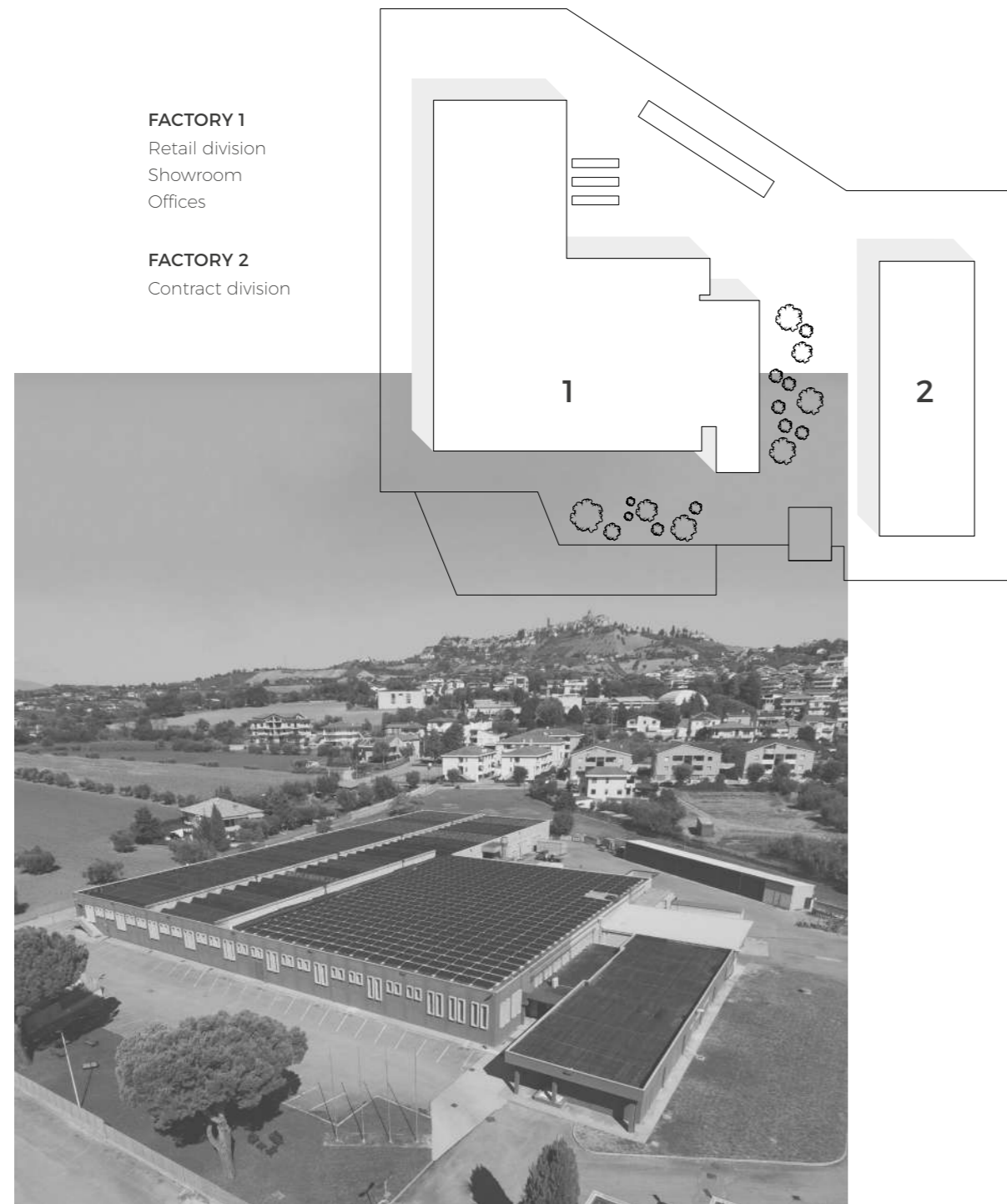

## COMPANY

Il brand Guzzini & Fontana nasce dall'incontro di Luca Guzzini, già Presidente della Teuco Guzzini, e Gary Fontana, titolare di OC Shanghai, due imprenditori con una lunga e consolidata esperienza nel settore dell'arredamento. L'azienda, in rapida ascesa, si è recentemente dotata di un nuovo stabilimento, provvisto di moderni macchinari 4.0, ed è in corso una notevole espansione che prevede la realizzazione di un secondo polo produttivo. Il concetto alla base della filosofia di GF Interiors è Made with Love in Italy e racchiude passione nella selezione dei materiali, cura nelle lavorazioni artigianali, attenzione per i dettagli e alta capacità tecnica per un prodotto dallo spiccato valore sartoriale.

The Guzzini & Fontana brand was born from the meeting of Luca Guzzini, former President of Teuco Guzzini, and Gary Fontana, owner of OC Shanghai, two entrepreneurs with a long and consolidated experience in the furniture sector. The rapidly growing company has recently equipped itself with a new plant, equipped with modern 4.0 machinery, and a significant expansion is underway which includes the construction of a second production center. The concept underlying the philosophy of GF Interiors is Made with Love in Italy and contains passion in the selection of materials, care in craftsmanship, attention to detail and high technical capacity for a product with a marked sartorial value.

## VALUES

Siamo un'azienda fondata sulla coesione, sullo spirito di squadra e sul rispetto per le capacità individuali. In Guzzini & Fontana profonda è la volontà di coinvolgimento, grande il senso di partecipazione: tutti possono trasmettere le loro competenze, condividere le loro esperienze. Funzionalità ed estetica, sistemi, prodotti che assolvono alle più svariate esigenze del contenere, collezioni progettate per soddisfare ogni necessità dell'abitare contemporaneo. Questi e altri obiettivi ci guidano e orientano la direzione del nostro sguardo. E ci aiutano a proiettarci sempre in avanti per offrire il meglio del futuro ai nostri clienti.

We are a company founded on cohesion, team spirit and respect for individual skills. In Guzzini & Fontana there is a deep desire for involvement, a great sense of participation: everyone can pass on their skills, share their experiences. Functionality and aesthetics, systems, products that fulfill the most varied storage needs, collections designed to meet every need of contemporary living. These and other objectives guide us and orient the direction of our gaze. And they help us to always project forward to offer the best of the future to our customers.

## LIVING IN JAZZ CONCEPT

Un catalogo dedicato alla zona giorno in cui il jazz, principale elemento d'ispirazione, si fonde a pieno con la raffinatezza e l'eleganza dei prodotti Guzzini e Fontana. Un vero e proprio percorso introspettivo che prende spunto dal vissuto di un artista jazz alla ricerca del proprio modo di vivere la casa. Si delineano così ambienti dalla spiccata personalità e dall'ipnotico carisma. Per GF Interiors jazz è "libertà di espressione", andare al di là dello spartito per ottenere performance uniche, esattamente come accade nelle collezioni, che sperimentano infinite "variazioni" di materiali, forme e finiture per dare ritmo e sonorità all'abitare contemporaneo.

A catalogue for Day Systems where Jazz is the main matter of inspiration, it perfectly fuses with the amazing sophistication and elegance of Guzzini & Fontana's products. A proper introspective path that is born for the jazz musician's personality to find a unique way of arranging a house. The result is a collection of environments that have a very strong personality and with a hypnotic charisma. Jazz represents for GF INTERIORS's freedom of expression, going beyond the music sheet to obtain unique performances, in the same way this happens in its collections where GF experiments infinite variations of materials, shapes and finishes that give rhythm and sound to an everyday living.

# 2

20

43

HOUSE OF  
CONTRABASS

# 7

76

87

HOUSE OF  
PIANO

# 12

138

151

HOUSE OF  
ELETRIC GUITAR

# 4

54

65

HOUSE OF  
FLUTE

# 10

114

125

HOUSE OF  
GUITAR

# 15

176

187

HOUSE OF  
TROMBONES

# 1

8

19

HOUSE OF  
ALTO SAXOPHONE

# 6

66

75

HOUSE OF  
TRUMPET

# 9

100

113

HOUSE OF  
SAX

# 13

152

163

HOUSE OF  
CLARINET

# 3

44

53

HOUSE OF  
KEYBOARD

# 8

88

99

HOUSE OF  
HORN

# 5

60

71

HOUSE OF  
DRUMS

# 11

126

137

HOUSE OF  
TUBA

# 14

164

175

HOUSE OF  
VOCALS

1<sup>st</sup> STORY. HOUSE OF ALTO SAXOPHONE





# 1<sup>st</sup> STORY

"Il Jazz è come il vino, quando è nuovo è solo per gli esperti, ma quando invecchia è per tutti."

"Jazz is like wine. When it is new, it is only for the experts, but when it gets older, everybody wants it."

Steve Lacy

---





Boiserie FLAT in bilaminato legno finitura Noce AM a tutta altezza con porta ESP CORE. Boiserie sporgente TEMPO con illuminazione Led e top FOLDING in laccato opaco Mercurio. Mobili contenitori in laccato opaco Visone e modulo a giorno in Grigio antracite.

Full-high FLAT boiserie and ESP CORE door in bilaminated Noce AM. Projecting TEMPO boiserie with Led on sides and top FOLDING in matt lacquered Mercurio finish. Cabinets in matt lacquered Visone and open space module in Grigio antracite matt finish.

Sistema NAKED con tramezzi e ante EVANS AIR in alluminio finitura nero opaco e vetro Fumè. Schienale centrale in vetro con decoro Wire. Schienali laterali in legno impiallacciato Frassino BL. Ripiani porta calici e porta bottiglie in alluminio nero opaco con illuminazione Led.

NAKED system with frame partition and EVANS AIR doors in aluminum black matt finish and Fumè glass. Back central panel in glass with decoration Wire. back panels on sides in veneer Frassino BL finish. Shelves for bottles and goblets in black matt aluminum with Led lighting.



# 1 TECHNICAL DATA

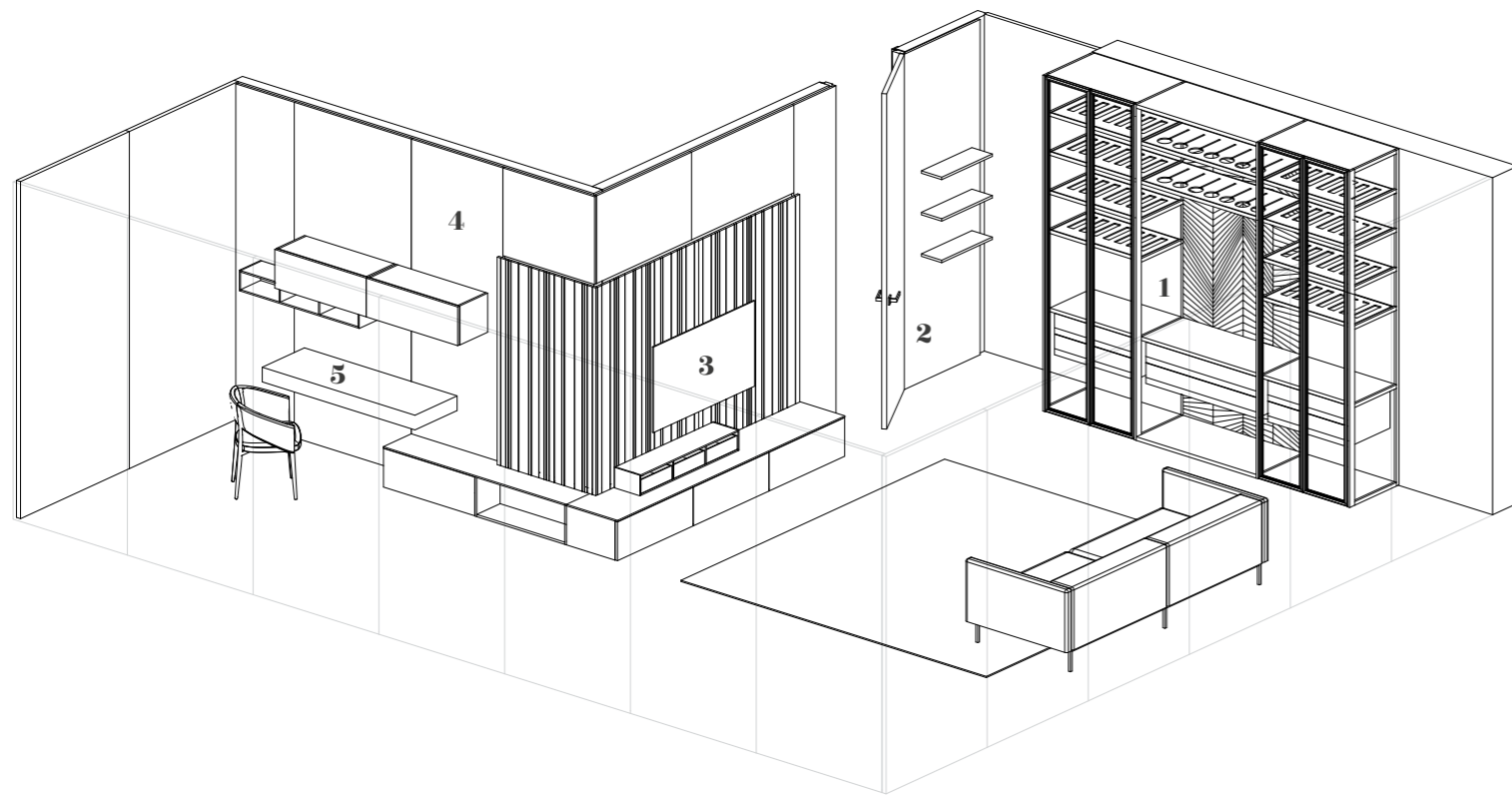

## 1 NAKED bar bar unit

Struttura con tramezzi e ante Evans Air in alluminio finitura nero opaco e vetro Fumè. Schienale centrale in vetro stopsol fumè con decoro Wire, schienali laterali in legno impiallacciato Frassino BL. Ripiani porta calici e porta bottiglie in alluminio nero opaco con illuminazione Led

Structure with frame partition and Evans Air doors in aluminum black matt finish and Fumè glass. Back central panel in stopsol fumè glass with Wire decoration, back panels on sides in veneer Frassino BL finish. Shelves for bottles and goblets in black matt aluminum with Led lighting

## 2 ESP CORE porta door

Porta in bilaminto Noce AM con maniglia Robocinqes neromat

Door in bilamintate Noce AM finish with Robocinqes handle matt black finish

## 3 TEMPO boiserie sporgente projecting boiserie

Boiserie sporgente con Led in laccato opaco Mercurio. Mobili contenitori in laccato opaco Visone e modulo a giorno in Grigio antacite

Projecting boiserie with Led lighting in matt lacquered Mercurio finish and cabinets in matt lacquered Visone finish, open space module in Grigio antracite

## 4 FLAT boiserie boiserie

Boiserie a tutta altezza in bilaminato Noce AM

Full-high boiserie in bilaminated Noce AM finish

## 5 FOLDING piano sospeso suspended top

Piano in laccato opaco finitura Mercurio

Top in matt lacquered Mercurio finish

2<sup>st</sup> STORY. HOUSE OF CONTRABASS



# 2<sup>nd</sup> STORY

"Il Jazz è vivere il momento"

"Jazz is about being in the moment"

Herbie Hancock

---







La parete living è costituita da boiserie TEMPO e mobili contenitori in laccato opaco Mercurio. Libreria in legno Frassino BL con ante EVANS AIR in alluminio nero e vetro Fumè, schienale in Mercurio.

Living wall consists of boiserie TEMPO and cabinets in matt lacquered Mercurio finish. Library in wood Frassino BL finish with EVANS AIR doors in matt black aluminum and Fumè glass, back panel in matt lacquered Mercurio finish.



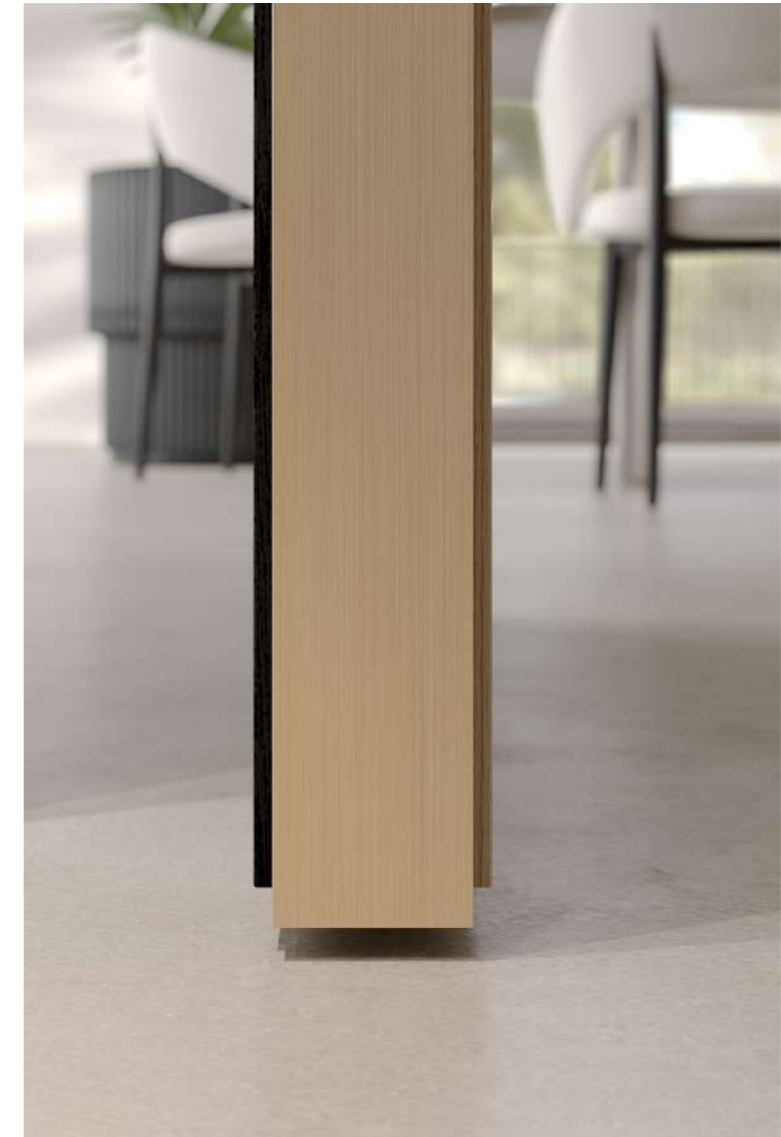

Il sistema MODWALL è costituito da una cornice frontale di 1 cm che ruota tutto attorno e che consente il distacco dei pannelli dal terreno, ciascuno di essi è sbattentato perimetralmente per consentire un perfetto alloggiamento all'interno del telaio e lasciare solamente 6 mm di spessore visibile. Ogni telaio è dotato di piedini di regolazione a terra e di viti per l'ancoraggio a soffitto.

MODWALL system is constituted by a 1 cm front frame that rotates all around and allows the panels to be detached from the ground, each of which is slammed around the perimeter to allow a perfect fit within the frame and leave only 6 mm of visible thickness. Each frame is equipped with ground adjustment feet and screws for anchoring to the ceiling.





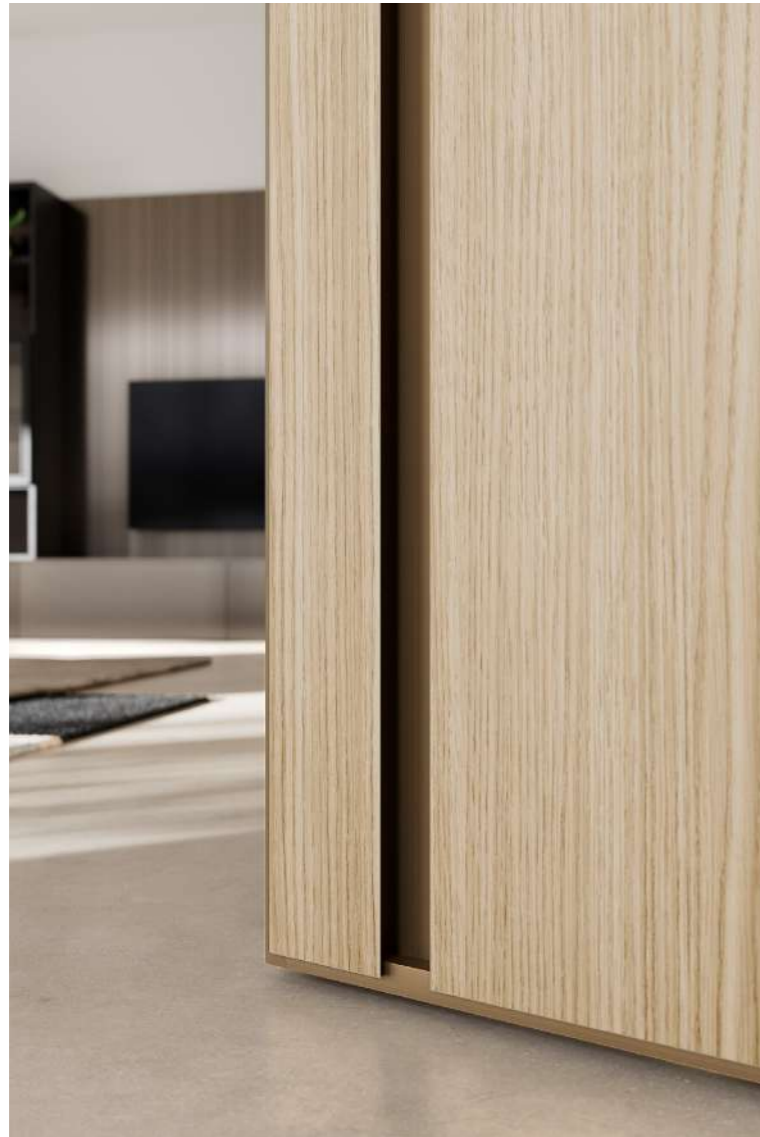

Dettaglio maniglia integrata con presa a taglio 45°. Telaio in alluminio finitura bronzo, pannello frontale in bilaminato finitura Rovere Japan e pannello posteriore in legno finitura Frassino BL.

Integrated handle detail with 45° cut grip. Aluminium frame in bronze finish, front panel in bilaminate wood Rovere Japan finish and back panel wood Frassino BL finish.





## MODWALL TRASVERSALITY

38

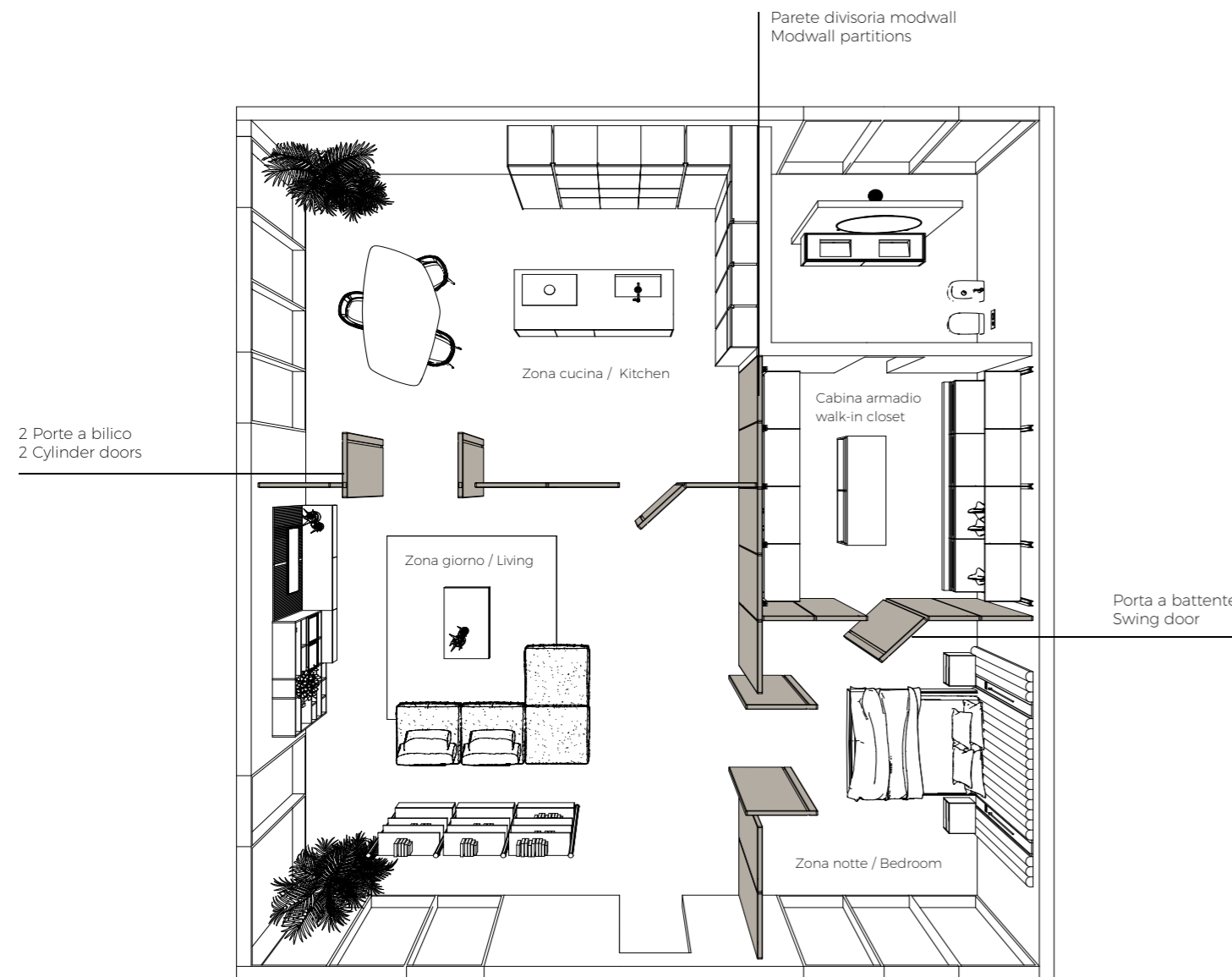

39

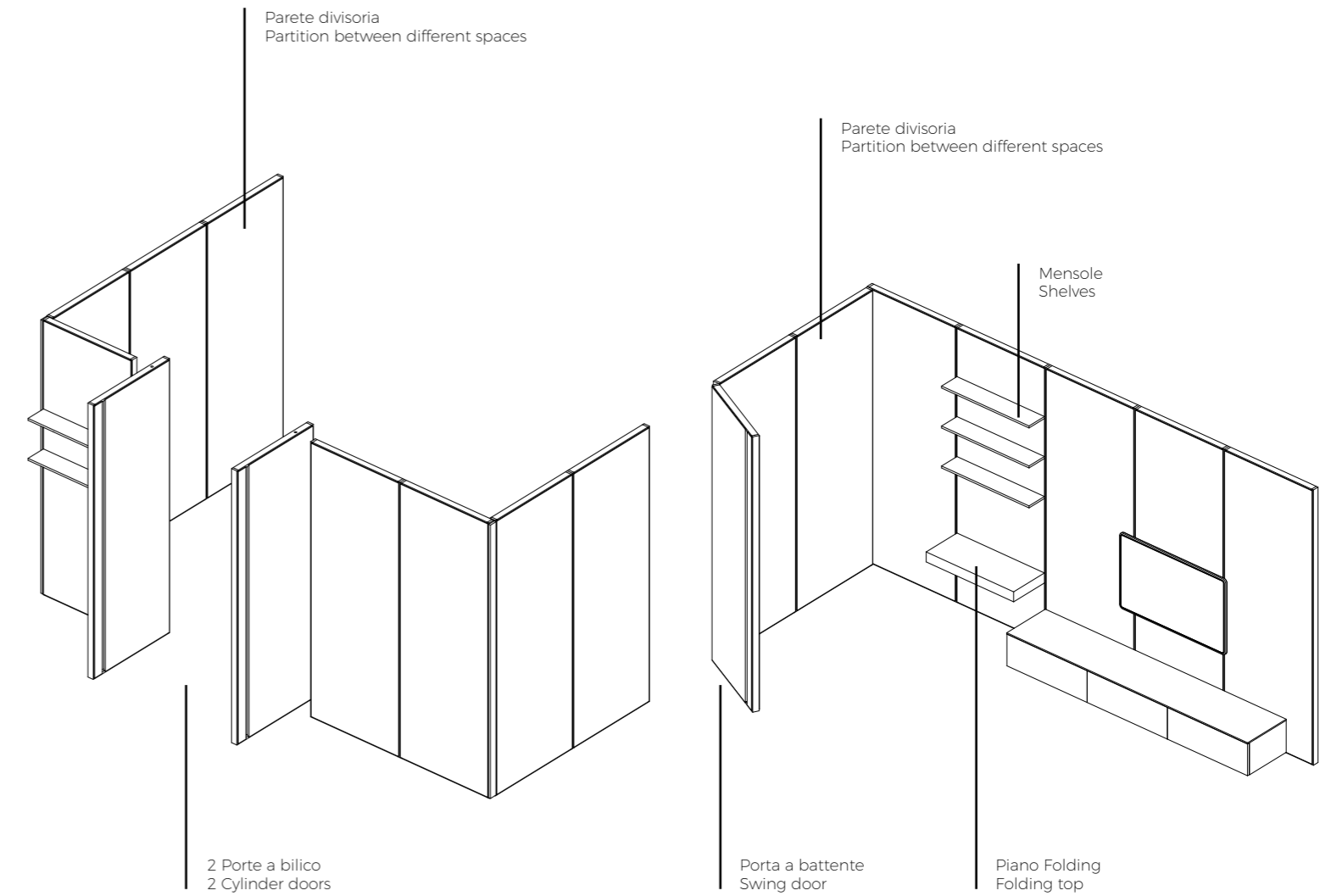

Un sistema pensato per consentire la massima trasversalità di ogni ambiente e per garantire al tempo stesso il cambiamento e la ridisposizione degli arredi. Delle vere e proprie pareti divisorie dividono gli ambienti della casa, grazie ai vari sistemi porta è possibile avere la giusta privacy unitamente a grandi aperture all'occorrenza. Un progetto dalle infinite sfaccettature che abbraccia l'intero abitare e dona carattere e forza ad ogni spazio. La sua versatilità fa sì che possa essere adattato e configurato in ogni contesto abitativo. Un'idea unica perfettamente al passo con il modo di vedere le l'abitare del futuro.

A system designed to allow maximum transversality of each room while at the same time guaranteeing the change and rearrangement of furniture. Real partition walls divide the rooms of the house, and thanks to the various door systems it is possible to have the right amount of privacy together with large openings when necessary. A design with infinite facets that embraces the entire living space and gives character and strength to every space. Its versatility means that it can be adapted and configured in any living context. A unique idea that is perfectly in step with the way of living in the future.



La libreria SKY8 consiste in un sistema di pali in alluminio con Led laterali dotati di ancoraggio a terra ed a soffitto. Dettaglio frontali delle basi cestone in laccato metallico finitura Mercurio arricchiti dal decoro Rubber.

The SKY8 bookcase consists of a system of aluminium poles with lateral LEDs equipped with floor and ceiling anchorage. Detail of drawer base unit fronts in metallic lacquered Mercury finish enriched with Rubber decoration.



## 2 TECHNICAL DATA

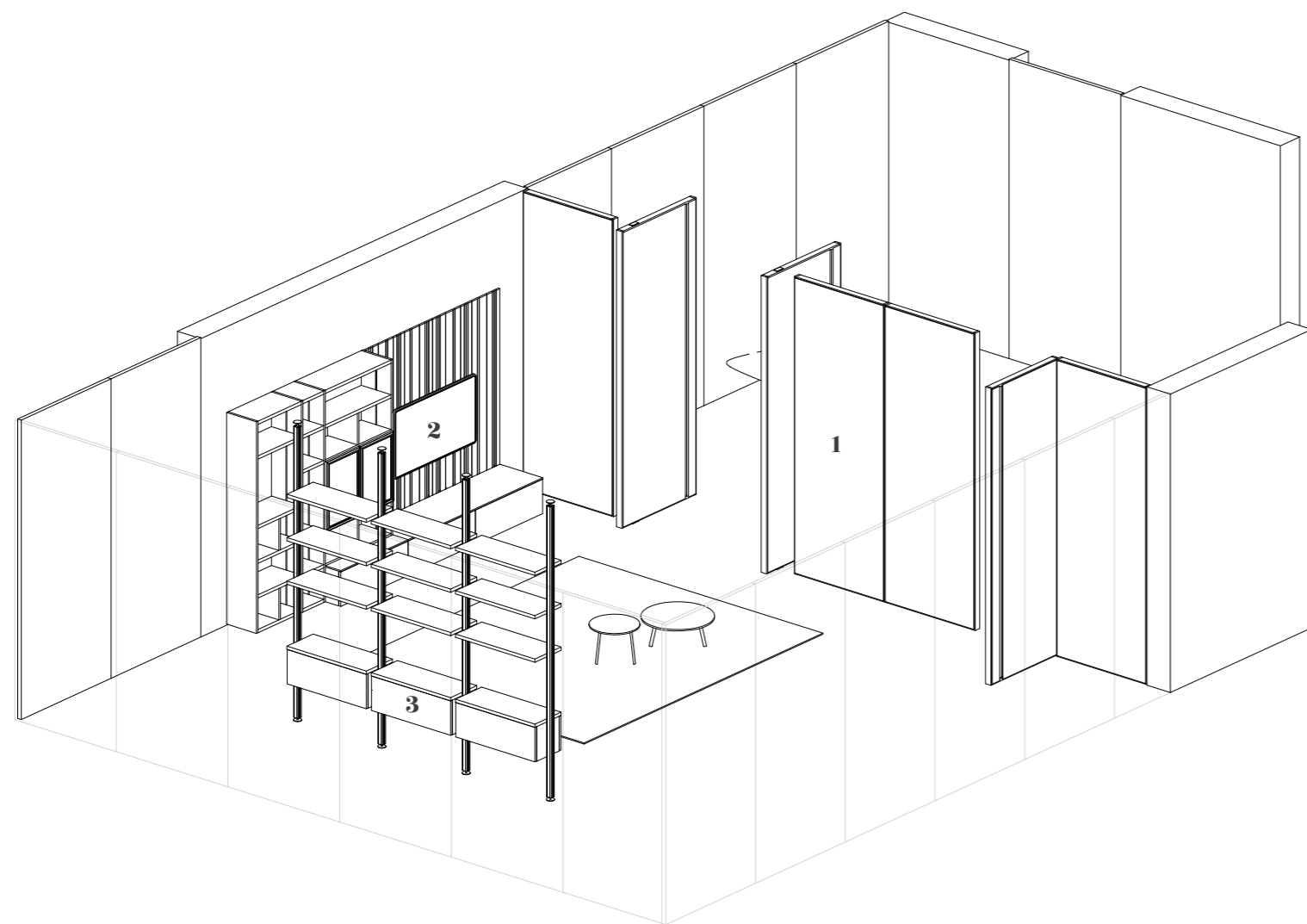

### 1 MODWALL sistema di interparete wall partition system

Struttura costituita da telaio in alluminio finitura bronzo, pannello frontale in bilaminato finitura Rovere Japan e pannello posteriore in legno finitura Frassino BL.

Structure consisting of bronze-finish aluminium frame, front panel in Rovere Japan finish bilaminate and back panel in wood Frassino BL finish.

### 2 LIVING mobili contenitori modules

Boiserie TEMPO e mobili contenitori in laccato opaco Mercurio. Libreria in legno Frassino BL con ante EVANS AIR in alluminio nero e vetro Fumè, schienale in Mercurio.

TEMPO boiserie and cabinets in matt lacquered Mercurio finish. Library in wood Frassino BL finish with EVANS AIR doors in matt black aluminum and Fumè glass, back panel in matt lacquered Mercurio finish.

### 3 SKY8 libreria palo pole library

Sistema di pali in alluminio nero con Led laterali dotati di ancoraggio a terra ed a soffitto. Basi cestone in laccato metallico finitura Mercurio arricchiti dal decoro Rubber.

Black aluminium pole system with lateral LEDs equipped with floor and ceiling anchorage. Basket bases in metallic lacquered Mercurio finish enriched with Rubber decoration.

3<sup>rd</sup> STORY. HOUSE OF KEYBOARD





## 3<sup>rd</sup> STORY

"Non è sbagliata la nota che sti suonando, è la nota che suonerai dopo che la rende giusta o sbagliata."

"It's not the note you play that's the wrong note, it's the note you play afterwards that makes it right or wrong."

Miles Davis

---





Composizione living costituita da boiserie FLAT in bilaminato Rovere CB. Mobili contenitori in laccato lucido Amarena. Pensili in bilaminato Rovere CB con ante EVANS AIR in alluminio laccato metallico Amarena e vetro Fumè.

Living composition consists of boiserie FLAT and cabinets in glossy lacquered Amarena finish. Wall units in bilaminated Rovere CB finish and EVANS AIR metallic lacquered aluminium doors Amarena finish and Fumè glass.

# 3

## TECHNICAL DATA

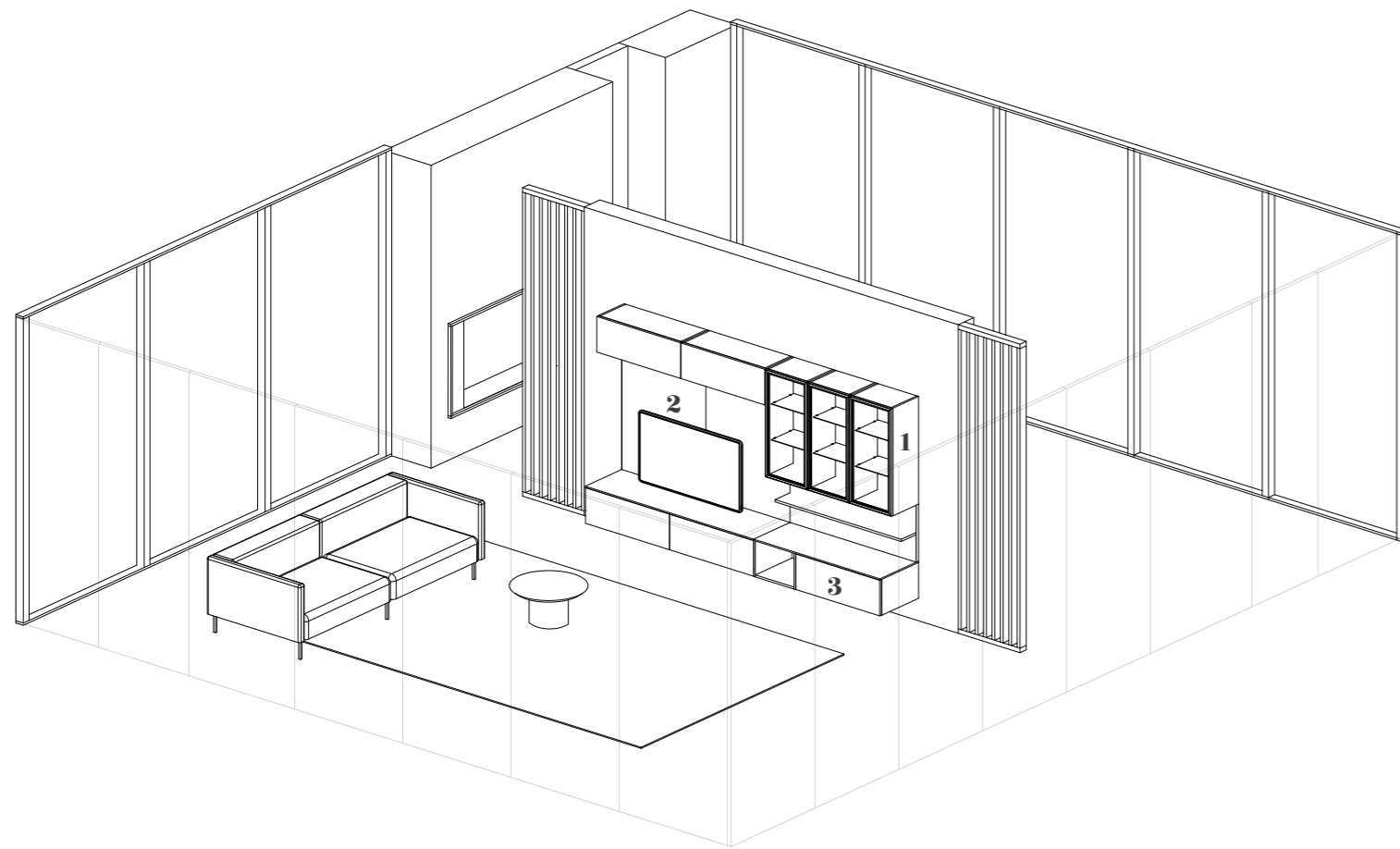

### 1 EVANS AIR pensili wall units

Struttura in bilaminato Rovere CB con ante EVANS AIR in alluminio laccato metallico Amarena e vetro Fumè. Ripiani in vetro Fumè

Structure in bilaminate Rovere CB finish and EVANS AIR metallic lacquered aluminum doors Amarena finish and Fumè glass. Shelves in Fumè glass

### 2 FLAT boiserie boiserie

Boiserie in bilaminato legno finitura Rovere CB

Boiserie in bilaminate wood Rovere CB finish

### 3 LIVING mobili contenitori modules

Struttura e ante in laccato lucido Amarena. Modulo a giorno in bilaminato Rovere CB

Structure and doors in glossy lacquered Amarena finish. Open space module in bilaminate Rovere CB finish

4<sup>th</sup> STORY. HOUSE OF FLUTE



# 4<sup>th</sup> STORY

"Il Jazz non è solo una stile musicale, è un modo di essere e di pensare."

"Jazz is not just music, it's a way of life, it's a way of being, a way of thinking."

Nina Simone

---







Libreria MISTY in bilaminato Visone con inserti nero opaco. Ante EVANS in alluminio nero opaco con vetro Fumè. Schienale della libreria in legno impiallacciato Rovere grigio Londra

MISTY Library Visone bilaminata with black finish inserts. EVANS door in black matt aluminum and Fumè glass. Back panel of the library in wood veneer Rovere grigio Londra finish





# 4

## TECHNICAL DATA



### 1 MISTY libreria library

Struttura bilaminato Visone con inserti alluminio nero e ante EVANS in alluminio nero opaco e vetro Fumè. Schienale in legno impiallacciato Rovere grigio Londra

Structure in Visone bilaminated with black finish inserts and EVANS doors in black aluminum and Fumè glass. Back panel in wood veneer Rovere grigio Londra

### 2 TEMPO boiserie boiserie

Boiserie in bilaminato Visone

Boiserie in bilaminated Visone finish

### 3 EVANS pensili wall units

Struttura in bilaminato Visone con ante Evans in alluminio nero opaco e vetro Fumè. Ripiani in vetro Fumè

Structure in Visone bilaminated with Evans doors in black matt aluminum and Fumè glass. Shelves in glass Fumè finish

### 4 LIVING mobili contenitori modules

Struttura in bilaminato Visone e ante in laccato opaco Visone

Structure in bilaminated Visone and door in matt lacquered Visone finish

### 5 JACO tavolino coffee table

Struttura in legno Rovere grigio Londra e top vassoio in laccato opaco Visone

Structure in veneer Rovere grigio Londra and top tray in matt lacquered Visone finish

5<sup>th</sup> STORY. HOUSE OF DRUMS





## 5<sup>th</sup> STORY

"La musica rappresenta la Natura, la natura rappresenta la vita, il jazz rappresenta la natura, il jazz è la vita."

'Music represents nature, nature represents life, jazz represents nature, jazz is life.'

Sonny Rollins

---





Composizione living costituita da boiserie TEMPO e mobili contenitori in laccato opaco Sahara BC. Boiserie FLAT con mensole e colonne in bilaminato Rovere Japan. Piano FOLDING in laccato opaco Bronzo.

Living composition is composted with boiserie TEMPO and cabinets in matt lacquered Sahara BC finish. Boiserie FLAT with shelves and high columns are in bilaminate Rovere Japan. FOLDING top in matt lacquered Bronzo finish.

# 5

## TECHNICAL DATA

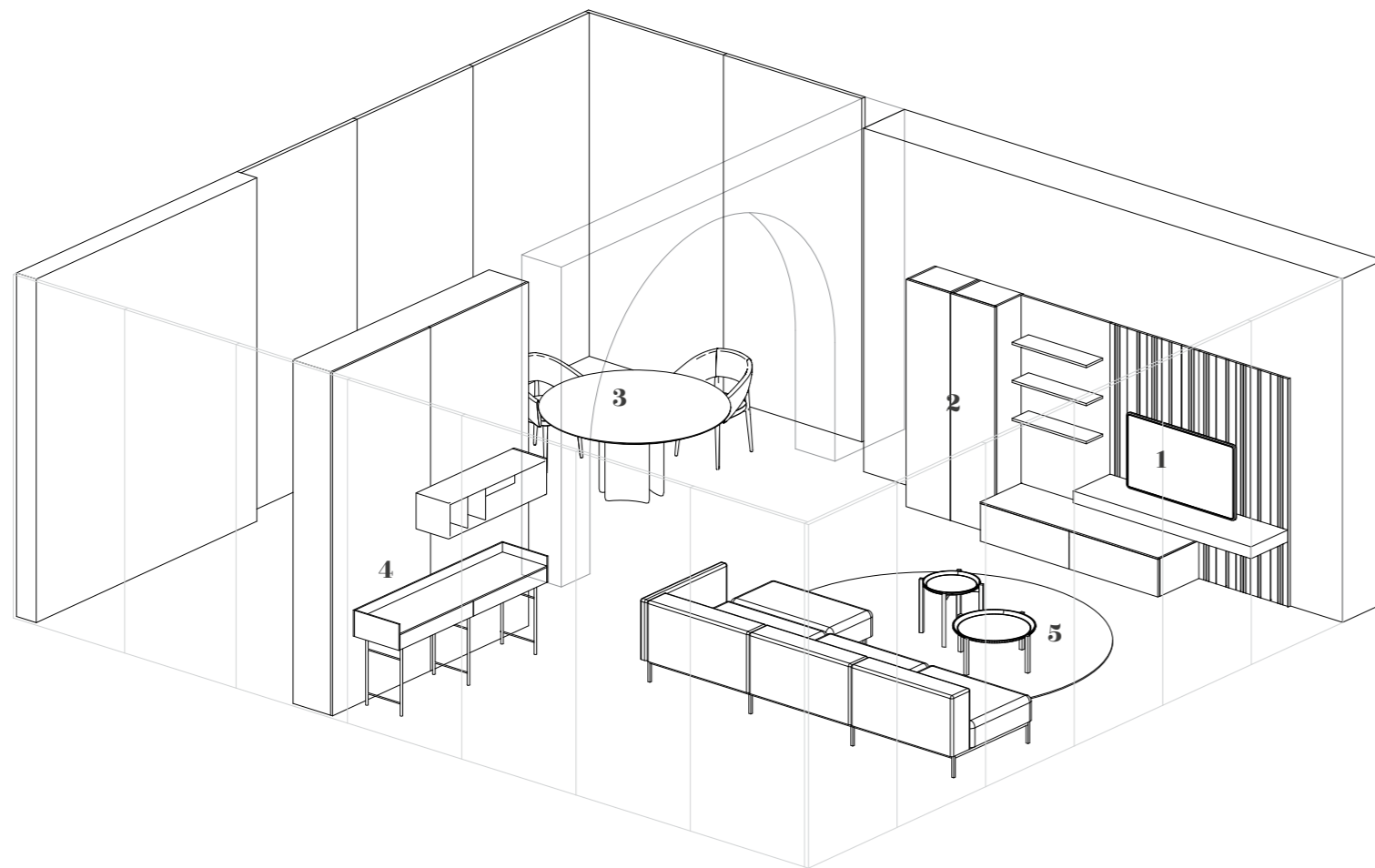

### 1 TEMPO e FLAT boiserie boiserie

Boiserie Tempo in laccato opaco Sahara BG e boiserie Flat in bilaminato Rovere Japan

Tempo boiserie in matt lacquered Sahara BG and boiserie Flat in bilaminate Rovere Japan finish

### 2 LIVING mobili contenitori modules

Struttura in bilaminato Lino e anta in laccato opaco Sahara BG. Ante colonne in bilaminato Rovere Japan. Piano Folding in laccato opaco Bronzo

Structure in bilaminate Lino and door in matt lacquered Sahara BG finish. High column doors in bilaminate Rovere Japan. Folding plan in matt lacquered Bronze finish

### 3 YASS tavolo tondo round table

Struttura e top laccato lucido Amarena

Structure and top glossy lacquered Amarena finish

### 4 O'DAY scrittoio desk

Basamento metallo laccato opaco Bronzo con cassetti e top laccato lucido Amarena. Modulo a giorno laccato opaco Bronzo

Structure matt lacquered metal Bronzo finish with drawers and top in glossy lacquered Amarena finish. Open space unit in matt lacquered Bronzo finish

### 5 JACO tavolino coffee table

Struttura e top in laccato opaco Nero e fianchi in laccato opaco finitura Bronzo

Matt lacquered Nero frame and top and matt lacquered Bronzo sides

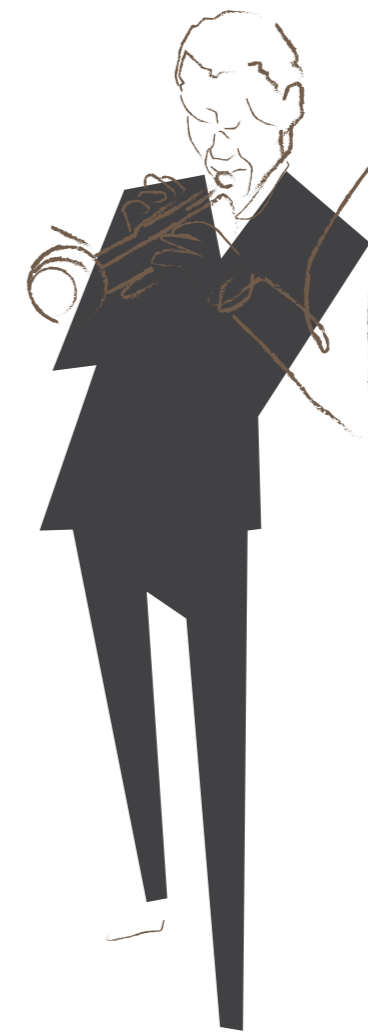
6<sup>th</sup> STORY. HOUSE OF TRUMPET

# 6<sup>th</sup> STORY

"I suoni che escono dalla tromba di un uomo sono parte di lui."

"My whole life, my whole soul, my whole spirit is to blow my horn."

Louis Armstrong

---

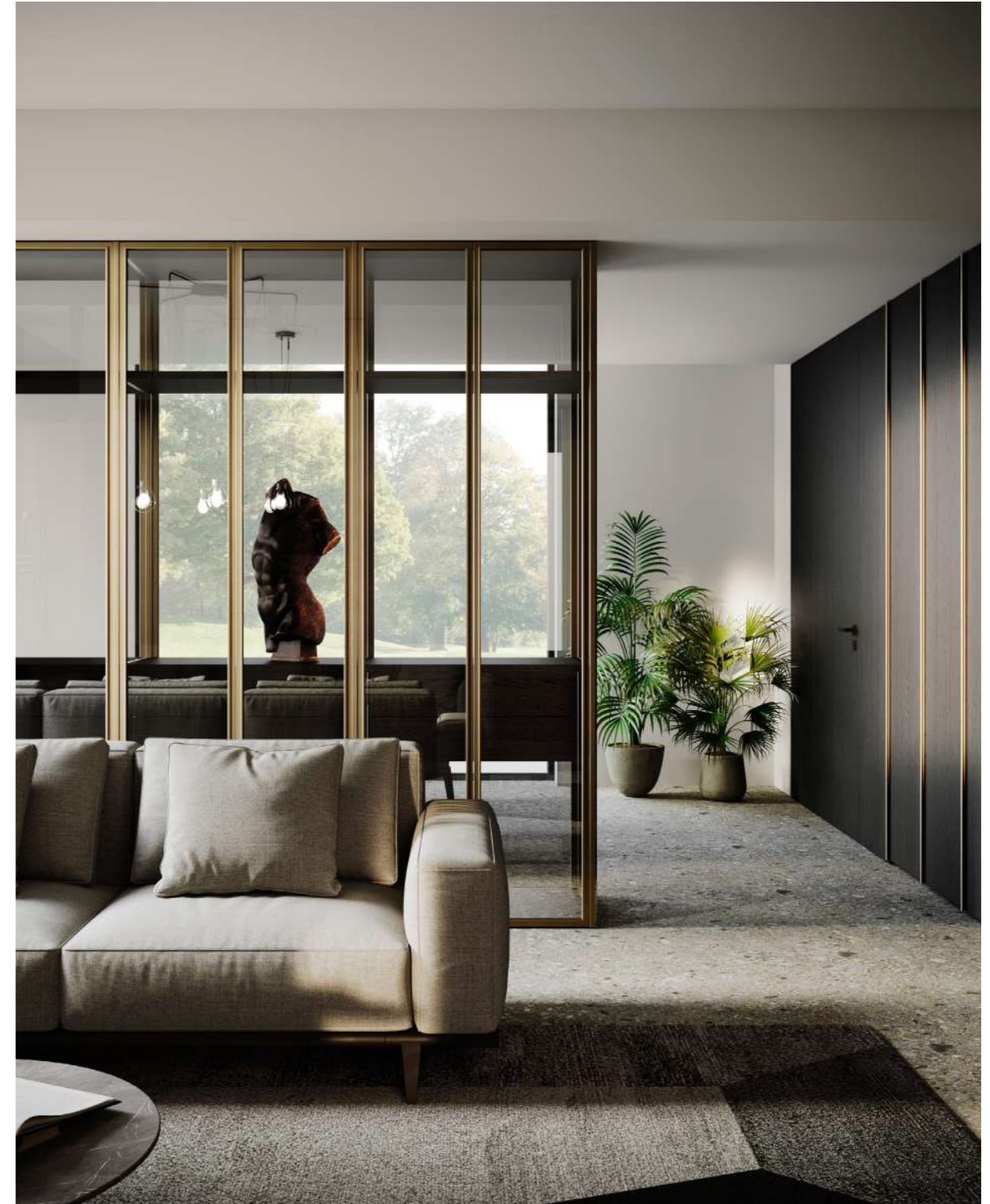



Libreria MISTY in legno Frassino BL con inserti in ottone, mobili contenitori in bilaminato Pietra GR, a seguire armadio Flat con maniglia Reflections bronzo e porta battente ESP Core.

MISTY Library in Frassino BL veneer with brass finish inserts, bilaminated cabinets in Pietra GR, next to it a Flat wardrobe with Reflections handle in bronze finish and ESP Core swing door.





Sistema NAKED in alluminio finitura bronzo e ante in vetro fumé. mobili contenitori in legno Frassino BL. Tavolo con basamento in metallo finitura bronzo e piano gres Marble grey opaco. Sedia BIG MAMA con struttura nero opaco e seduta in velluto grey.

NAKED System in aluminum bronze finish with doors in fumé glass, cabinets in Frassino BL. Table with metal structure in bronze colour and ceramic top Marble-Grey matt finish. BIG MAMA Chair with matt black frame and grey velvet seat.

# 6

## TECHNICAL DATA

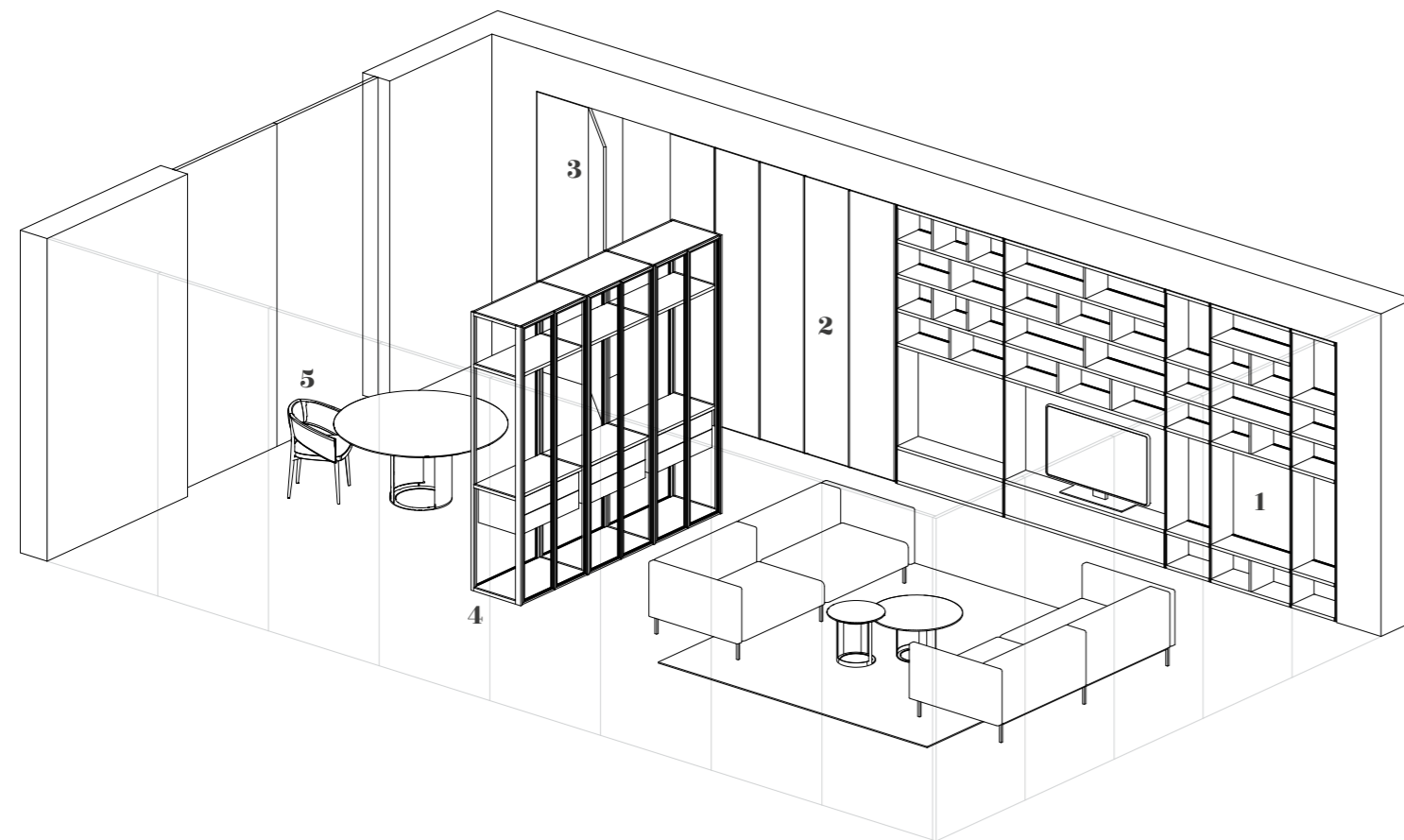

### 1 MISTY *libreria library*

Struttura legno impiallacciato Frassino BL con profili alluminio bronzo e ante Bilaminato Pietra GR

Structure in Frassino BL veneer with brass finish inserts and bilaminated cabinets in Pietra GR

### 2 FLAT *armadio wardrobe*

Struttura bilaminato Lino Grey e ante legno impiallacciato Frassino BL con maniglia Reflections bronzo

Structure in Lino Grey bilaminated and doors Frassino BL veneer with Reflections handle in bronze finish

### 3 ESP CORE *porta door*

Porta legno impiallacciato Frassino BL con maniglia Robocinques neromat

Door in Frassino BL veneer with Robocinques handle matt black finish

### 4 NAKED *sistema system*

Struttura con tramezzi in alluminio finitura Bronzo, ante Evans Air in alluminio finitura nero opaco e vetro fumè

Structure with frame partition in aluminum Bronze finish, Evans Air doors in aluminum black matt finish and fumè glass

### 5 BIG MAMA *sedia chair*

Struttura legno nero opaco e seduta velluto Viky 34

Structure matt black wood and velvet seat Viky 34 finish

7<sup>th</sup> STORY. HOUSE OF PIANO





## 7<sup>th</sup> STORY

"Credo si possa utilizzare il pianoforte come strumento unico capace di esprimere ogni possibile concetto musicale".

"I believe in using the entire piano as a single instrument capable of expressing every possible musical idea."

Oscar Peterson

---





Mobili contenitori in laccato metallico graffiato Brunito con vani aperti e cassetti in pelle. Vetrine EVANS AIR in alluminio nero opaco e vetro fumè. Boiserie FLAT in bilaminato legno Mandorlo.

Metal lacquered cabinets in scratched Brunito finish and with open leather units. EVANS AIR glass cabinets in black matt aluminum and fumè glass. Boiserie FLAT in Mandorlo bilaminate wood.

Libreria in bilaminato Lino Grey con schiena in bilaminato legno Mandorlo e ante in laccato metallico graffiato Brunito. Madia MISTY TRAY con struttura nero opaco e ante in bilaminato legno Mandorlo.

Bilaminato Lino Grey with back panels in Mandorlo wood bilaminate and doors in scratched Brunito lacquer. MISTY TRAY cupboard with black matt aluminum frame, bilaminate doors in Mandorlo.

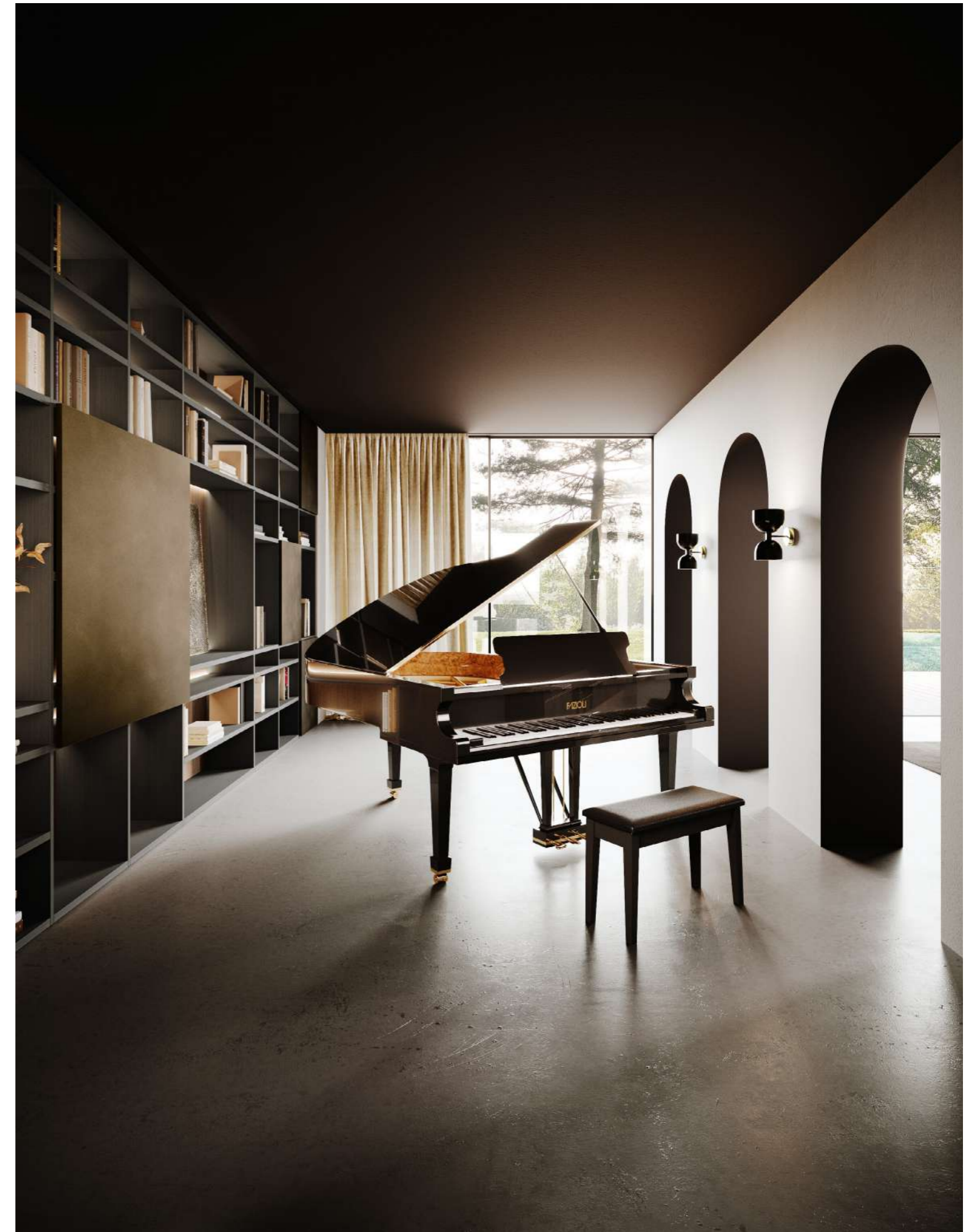





## TECHNICAL DATA

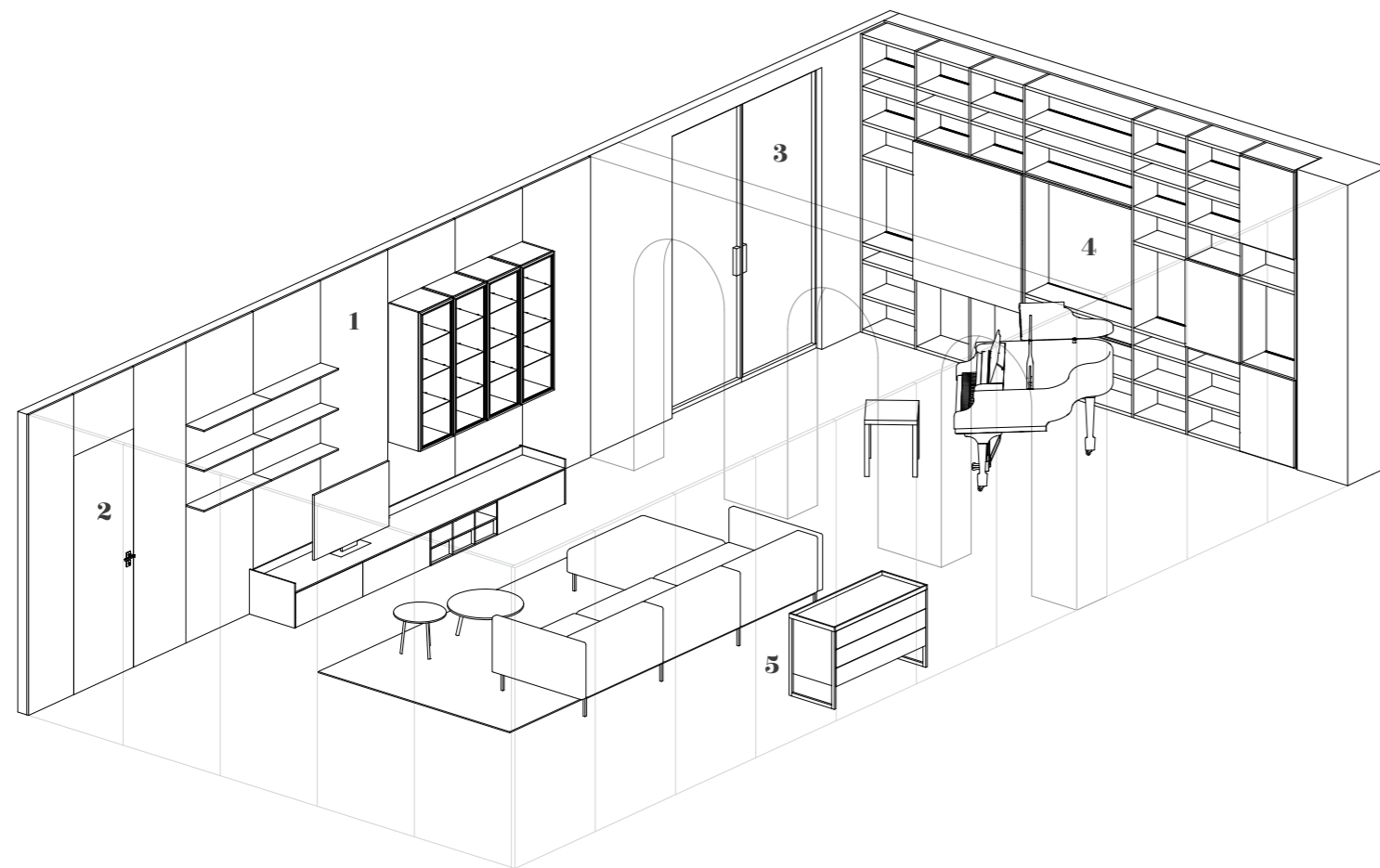

### 1 LIVING *mobili contenitori* modules

Struttura bilaminato legno Mandorlo e ante laccato metallo graffiato Brunito, vetrina Evans Air in alluminio nero opaco e vetro Fumè

Structure in wood bilaminate Mandorlo finish and doors scratched metal lacquered Brunito finish, Evans Air glass unit in aluminum matt black finish and Fumè glass

### 2 ESP CORE *porta* door

Porta bilaminato legno Mandorlo con maniglia Robocinques neromat

Door in wood bilaminate Mandorlo with Robocinques handle matt black finish

### 3 ESP CRISTAL *porta vetro* glass door

Porta alluminio scorrevole nero e vetro Extra clear con maniglia Lambda

Sliding door in aluminum black finish and Extra clear glass with Lambda handle

### 4 LIBRARY *libreria* library

Struttura bilaminato Lino Grey con schienale bilaminato legno Mandorlo e ante laccato metallo graffiato Brunito

Structure in bilaminate Lino grey finish with back panel wood bilaminate Mandorlo finish and scratched metal lacquered Brunito finish doors

### 5 MISTY TRAY *madia* sideboard

Struttura in alluminio nero opaco, vassoio laccato opaco nero e ante bilaminato legno Mandorlo

Aluminium black matt structure with tray in matt black lacquered finish and doors in wood bilaminate Mandorlo finish

8<sup>th</sup> STORY. HOUSE OF HORN

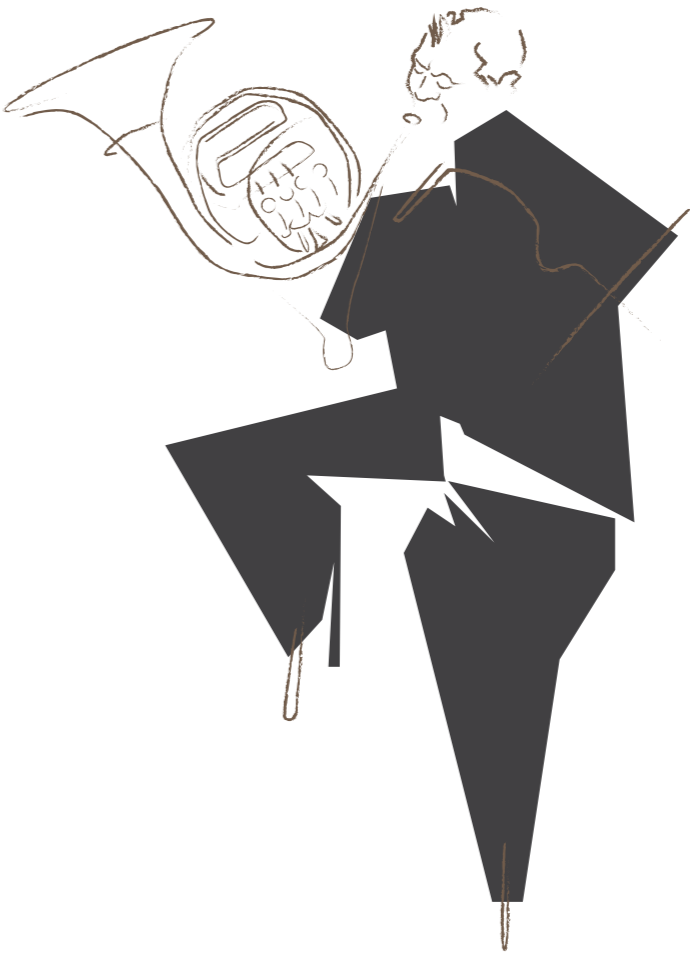

# 8<sup>th</sup> STORY

“Mi ci è voluta una vita intera per imparare cosa non suonare”

“It has taken all my life to learn what not to play”

Dizzy Gillespie

---







Parete living in laccato opaco Sahara BC, vetrina EVANS AIR con ante in alluminio Bronzo e vetro Fumé, vano Tv in legno Rovere TC e schiena in gres Taj Mahal opaco.

Living system in Matt lacquer Sahara BC, EVANS AIR glass cabinets with doors in Bronze aluminum finish and Fumé glass, tv space in veneer Rovere TC and back panel in Taj Mahal matt ceramic surface.

Scrivania O' DAY con struttura in metallo nero opaco e ante in legno Rovere TC. Tavolo OTIS con basamento in legno Rovere TC rigato e piano in gres Fokos Sale opaco. Sedia BIG MAMA con struttura nero opaco e seduta in velluto Viky 08. Porta scorrevole con telaio alluminio nero opaco e vetro extra clear ESP CRISTAL.

O'DAY desk with metal frame in matt black metal and Rovere TC doors. OTIS Table with striped Rovere TC base and Fokos Sale matt ceramic top. BIG MAMA Chair with matt black frame and Viky 08 velvet seat. Sliding door with matt black anodized frame and extra clear glass ESP CRISTAL.



## 8

## TECHNICAL DATA

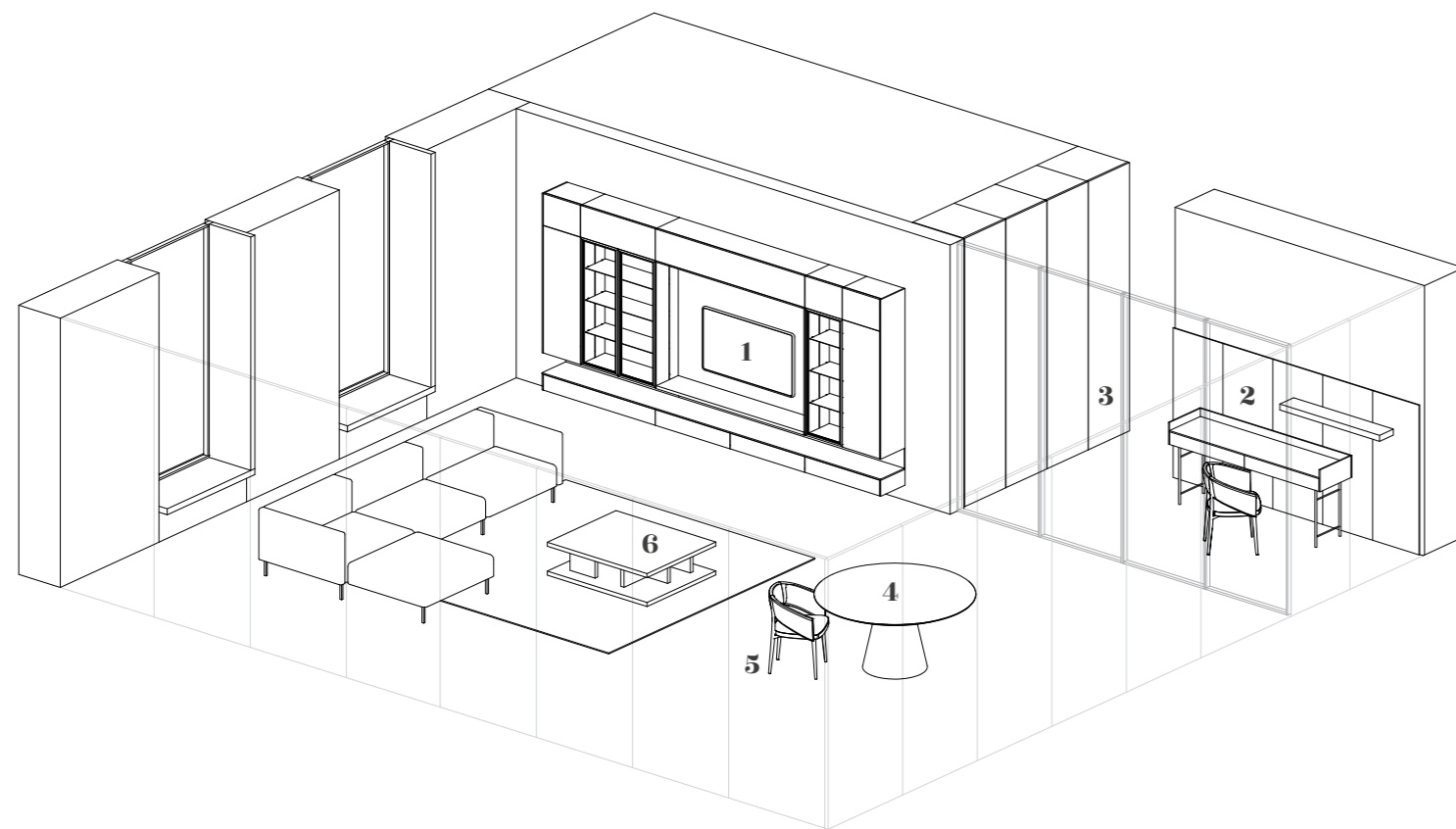
1 **LIVING** mobili contenitori modules

Struttura bilaminato Lino e ante laccato opaco Sahara BG. Struttura vetrina legno impiallacciato Rovere TC e ante Evans Air alluminio Bronzo e vetro Fumè

Structure in bilaminated Lino finish and doors matt lacquered Sahara BG finish. Glass unit structure wood veneer Rovere TC finish and Evans Air doors in aluminum Bronze finish with Fumè glass

2 **O'DAY** scrittoio desk

Basamento metallo laccato opaco nero con cassetti e top legno impiallacciato Rovere TC

Structure matt lacquered metal black finish with drawers and top in wood veneer Rovere TC finish

3 **ESP CRISTAL** porta vetro glass door

Porta alluminio scorrevole nero e vetro Extra clear con maniglia Lambda

Sliding door in aluminum black finish and Extra clear glass with Lambda handle

4 **OTIS** tavolo table

Struttura legno impiallacciato Rovere TC rigato e top gres Fokos Sale

Structure in ribbed wood veneer Rovere TC finish and top in gres Fokos Sale finish

5 **BIG MAMA** sedia chair

Struttura in legno nero opaco e seduta velluto Viky 08

Structure matt black wood and grey velvet Viky 08 finish seat

6 **ALFIE** tavolino coffee table

Piano legno impiallacciato Rovere TC e divisori laccato opaco Sahara BG

Top in wood veneer Rovere TC finish and dividers in matt lacquered Sahara BG finish

9<sup>th</sup> STORY. HOUSE OF SAX





## 9<sup>th</sup> STORY

"Non suonare il sassofono lascia che sia lui a suonare te."

"Don't play the saxophone. Let it play you."

Charlie Parker

---





Libreria in legno Noce CN con mobili contenitori in bilaminato Beton VS. Boiserie ALWAYS in legno Noce CN rigato con desk stessa finitura e piano in eco-pelle Pandora 02, vetrina con ante EVANS AIR in alluminio nero e vetro fumé. Coffee table ALFIE con piano in legno Noce CN e divisori in bilaminato Beton VS.

Library in Noce CN veneer with cabinets in Bilaminate Beton VS. Boiserie ALWAYS in striped wood veneer Noce CN with desk in same finish and top in eco-leather Pandora 02, EVANS AIR glass doors cabinet with black matt frame and fumé glass. ALFIE table with Noce CN top and internal divisions in bilaminate Beton VS.

Tavolo YASS con struttura nero opaco e piano in gres Statuarietto opaco. Sedia BIG MAMA con struttura nero opaco e seduta in velluto grey. Madia STAGE con basamento nero opaco, ante laccato opaco Verde FR e maniglia Noce CN.

YASS Table with matt black structure and top in matt ceramic Statuarietto. Big MAMA CHAIR with matt black frame and grey velvet seat. STAGE sideboard with matt black basement, lacquered doors Verde FR and Noce CN handles.



# 9

## TECHNICAL DATA

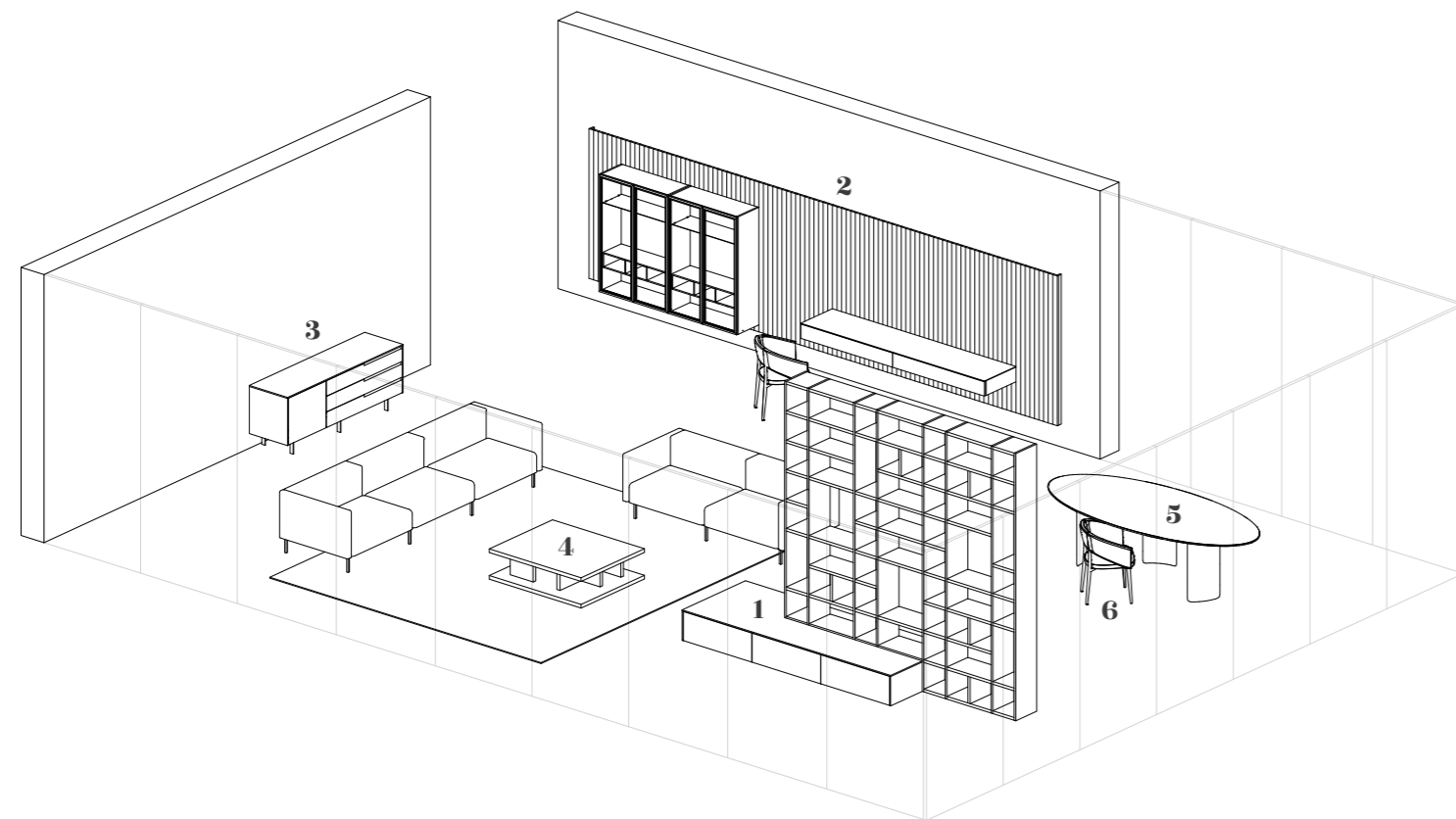

### 1 LIBRARY *libreria library*

Struttura legno impiallacciato Noce CN e ante Bilaminato Beton VS

Structure in wood veneer Noce CN finish e doors in bilaminate Beton VS finish

### 2 LIVING *mobili contenitori modules*

Boiserie Always in legno impiallacciato Noce CN con doge. Struttura vetrina e desk legno impiallacciato Noce CN e ante Evans Air in alluminio nero e vetro Fumè, top eco-pelle Pandora O2

Boiserie Always in striped wood veneer Noce CN finish. Glass unit and desk in wood veneer Noce CN. Evans Air doors in aluminum black finish and Fumè glass, top in eco-leather Pandora O2 finish

### 3 STAGE *madia sideboard*

Basamento metallo nero opaco con ante e top laccato opaco Verde FR con maniglia Noce CN

Structure in metal matt black finish with doors and top matt lacquered Verde FR with handle Noce CN finish

### 4 ALFIE *tavolino coffee table*

Piano legno impiallacciato Noce CN e divisori bilaminato Beton VS

Top in wood veneer Noce CN finish and dividers in bilaminate Beton VS finish

### 5 BIG MAMA *sedia chair*

Struttura metallo nero opaco e seduta velluto Viky 10

Structure matt black finish and Viky 10 velvet seat

10<sup>th</sup> STORY. HOUSE OF GUITAR



# 10<sup>th</sup> STORY

"Ho sempre voluto collegare la mia chitarra alle emozioni umane"

"I wanted to connect my guitar to human emotions."

B.B. King

---







Libreria GENTLE sospesa in laccato metallico liscio Peltro e schiena in bilaminato legno Mandorlo, cassetti finitura eco-pelle Bordeaux.

Suspended GENTLE library in smooth Metal lacquer Peltro color and back panel in Mandorlo Bilaminated, drawers in eco-leather Bordeaux finish.

134

Dettaglio modulo GENTLE con anta scorrevole in finitura laccato metallico liscio Peltro e schiena in bilaminato legno Mandorlo. Tavolo OLIVER con basamento in laccato opaco nero. SEDIA BIG Mama con struttura nero opaco e seduta in velluto Viky 34.

Detail of GENTLE with sliding door in smooth Metal Lacquer Peltro color and bilaminate back panel Mandorlo. Table OLIVER in matt lacquered black finish. BIG MAMA Chair with matt black frame and Viky 34 velvet seat.



135



# 10

TECHNICAL DATA

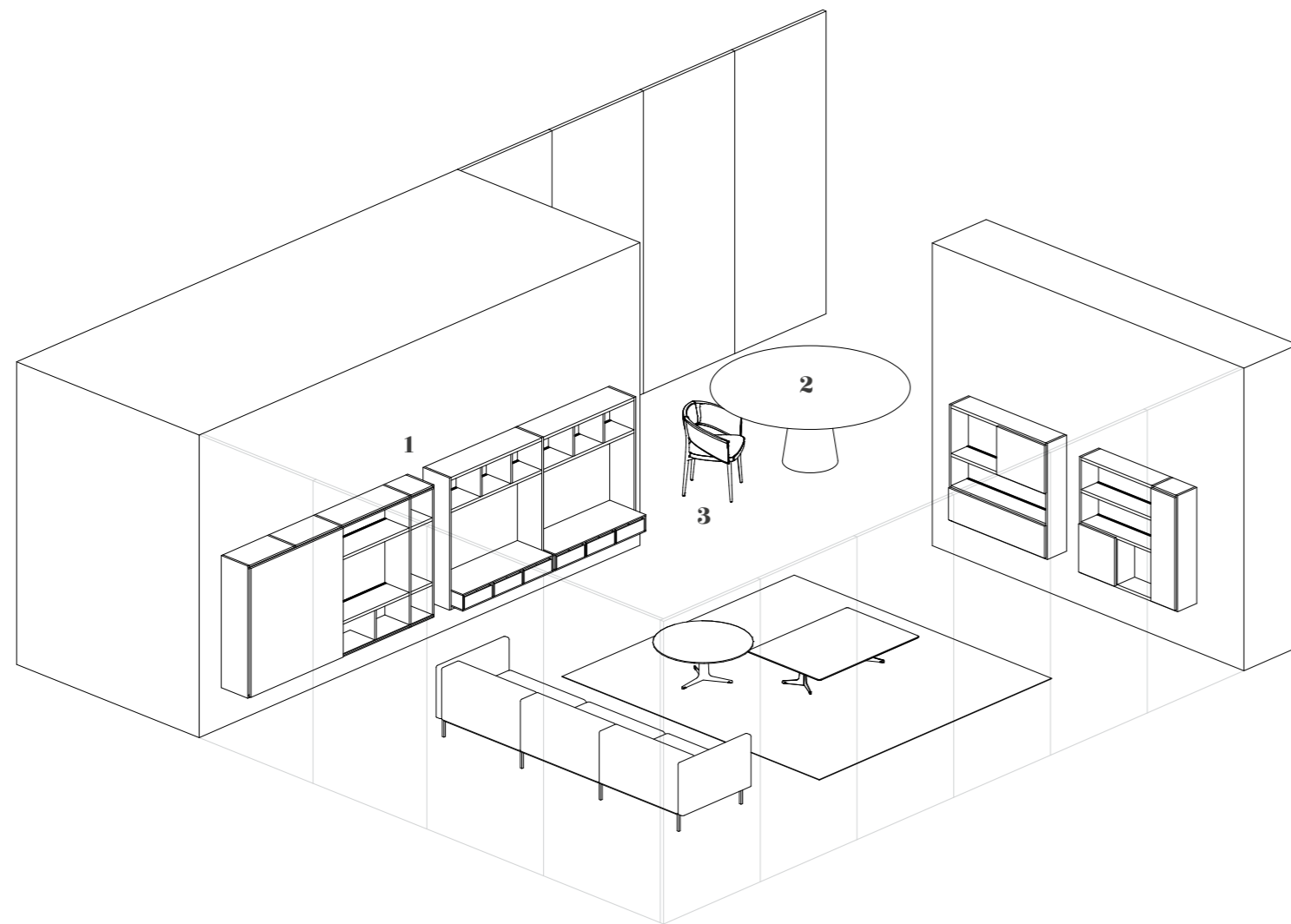

## 1 LIBRARY *libreria library*

Struttura e ante laccato metallico liscio Peltro e schiena bilaminato legno Mandorlo, cassetti eco-pelle Bordeaux

Structure and doors metal lacquered Peltro finish, back panels in wood bilaminated Mandorlo finish, drawers in eco-leather Bordeaux finish

## 2 OLIVER *tavolo table*

Struttura e top laccato opaco Nero

Structure matt lacquered Black finish

## 3 BIG MAMA *sedia chair*

Struttura metallo nero opaco e seduta velluto Viky 34

Structure matt black finish and Viky 34 velvet seat

11<sup>th</sup> STORY. HOUSE OF TUBA





## 11<sup>th</sup> STORY

“Non suonare il sassofono lascia che sia lui a suonare te.”

“Don't play the saxophone. Let it play you.”

Charlie Parker

---





Parete living in laccato opaco Grigio LV, vetrina con ante EVANS AIR in alluminio nero e vetro Fumé, moduli sospesi in laccato opaco Grigio LV rigato e legno Noce CN.

Living system in matt lacquer Grigio LV, EVANS AIR glass doors in black matt aluminum and Fumé glass, suspended wall cabinets Grigio LV lacquered with stripes and Noce CN wood veneer.

Tavolo YASS con struttura nero opaco e piano in gres Emperador opaco. Sedia BIG MAMA con struttura nero opaco e seduta in velluto grey.

YASS table with structure matt black and tabletop in gres Emperador matt. BIG MAMA Chair with matt black frame and grey velvet seat.

---



Madia ELLINGTON & Base con basamento nero opaco, ante laccato opaco Grigio LV rigato e liscio, piano in legno Noce CN.

ELLINGTON & Base Cupboard with matt black legs-frame, doors in Grigio LV lacquer with and without stripes, top in Noce CN veneer.



## 11

## TECHNICAL DATA

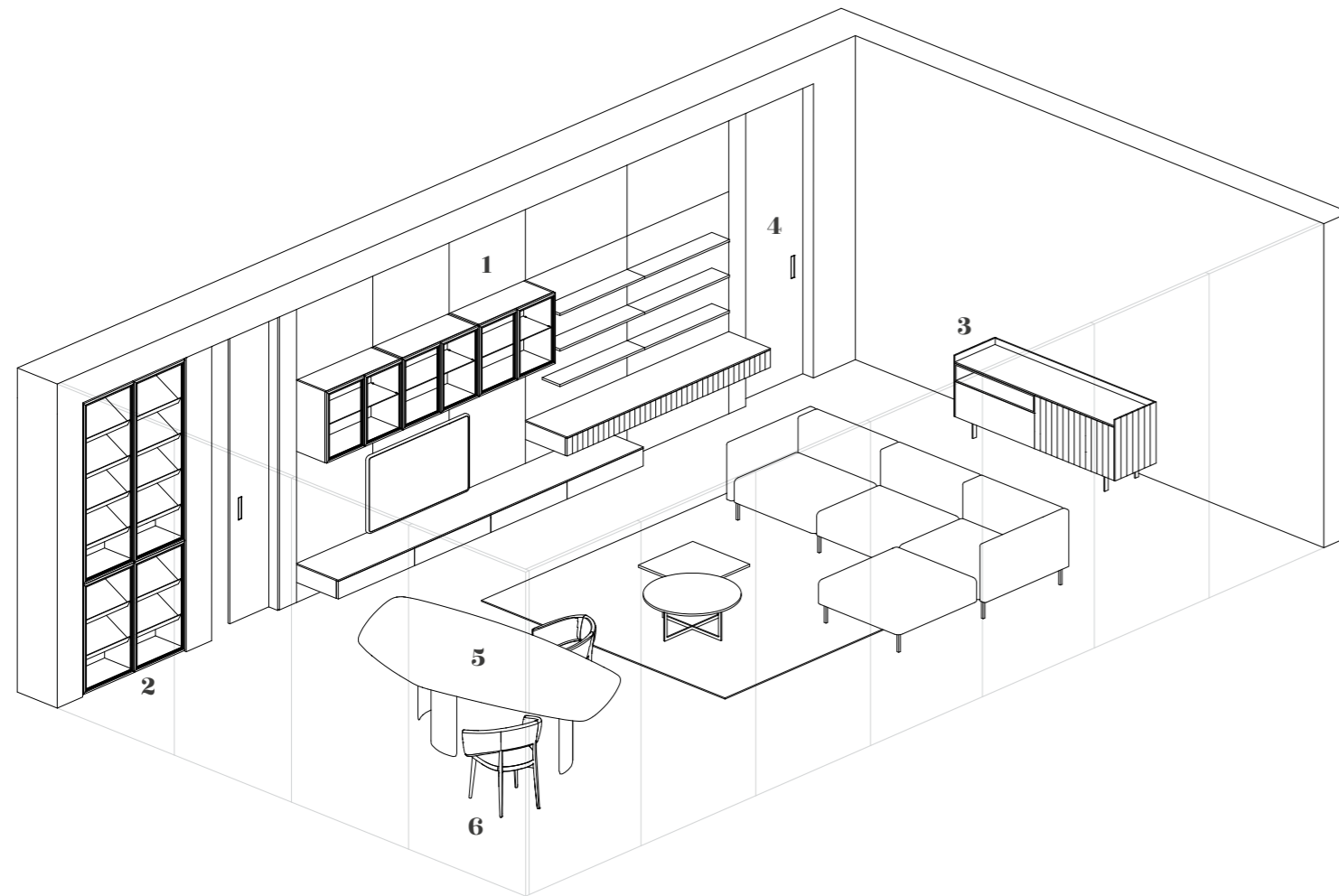
1 **LIVING** mobili contenitori modules

Boiserie e ante Always con effetto rigato laccato opaco Grigio LV, boiserie Flat e ante legno impiallacciato Noce CN, ante Evans Air in alluminio nero opaco e vetro Fumè seamless

Boiserie and doors Always striped matt lacquered Grigio LV finish, boiserie Flat and doors in wood veneer Noce CN finish, Evans Air glass unit in aluminum matt black finish and Fumè glass seamless

2 **WINE UNIT** cantina wine unit

Struttura legno impiallacciato Frassino BL, anta vetrina Evans Air alluminio nero opaco e vetro Fumè seamless

Structure in wood veneer Frassino BL finish, Evans Air door in aluminum matt black finish and Fumè glass seamless

3 **ELLIGTON AND BASE** madia sideboard

Basamento metallo nero opaco con ante e top laccato opaco Grigio LV con effetto rigato e legno impiallacciato Noce CN

Structure metal in matt black finish with doors and top matt lacquered Grigio LV with ribbed effect and wood veneer Noce CN finish

4 **ESP CORE** porta door

Porta legno impiallacciato Noce CN con maniglia Hollow

Wood veneer Noce CN finish door with Hollow handle

5 **BIG MAMA** sedia chair

Struttura in legno nero opaco e seduta velluto Viky 09

Structure in matt black wood and Viky 09 velvet seat

12<sup>th</sup> STORY. HOUSE OF ELECTRIC GUITAR



# 12<sup>th</sup> STORY

"Per rendere le cose interessanti a volte accordo la chitarra a caso così da non poter prevedere cosa ne uscirà"

"Just to keep it interesting I'll tune the guitar randomly, so I don't know what's going to come out."

Jim Hall

---

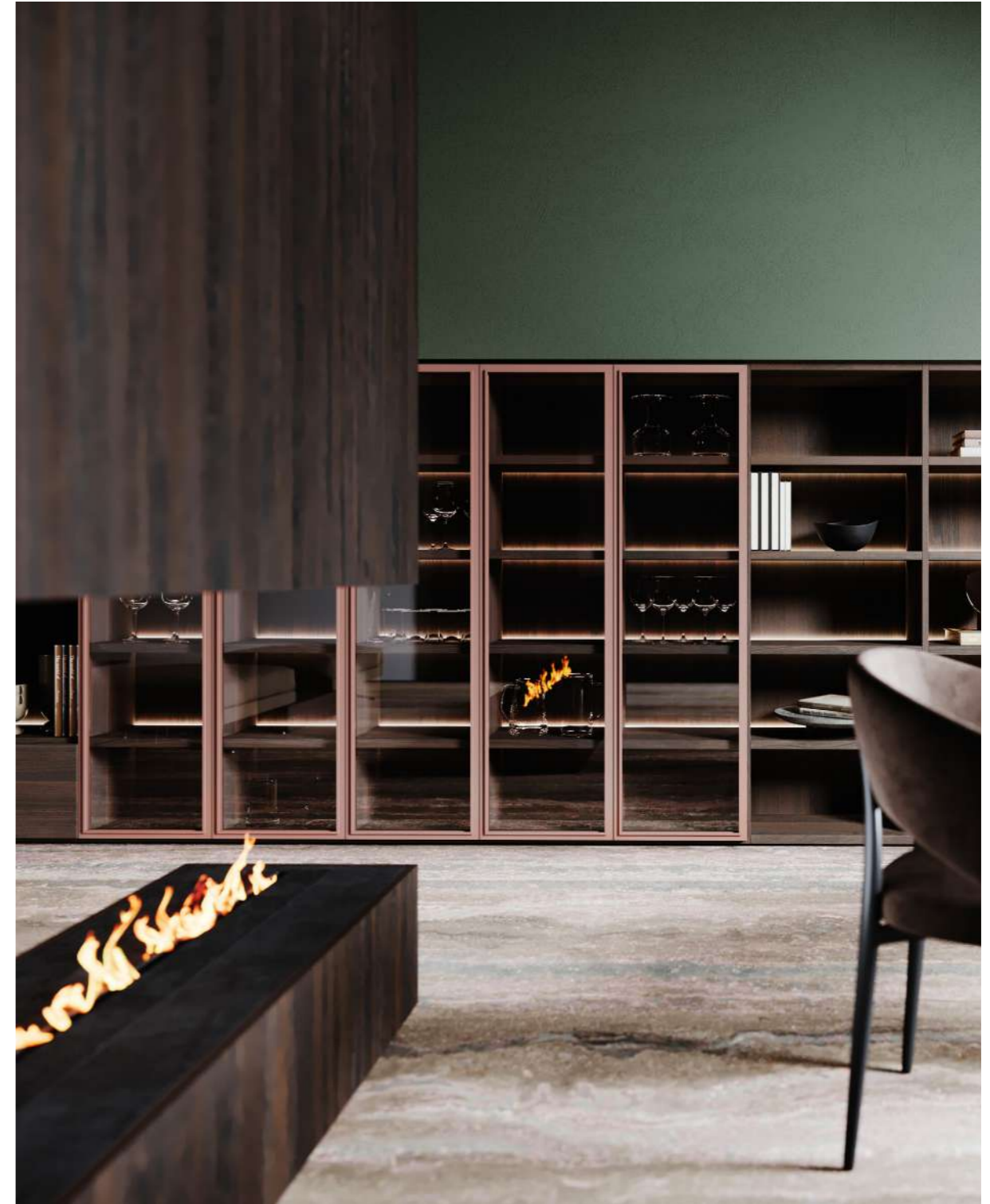





Libreria in legno Rovere TC, vano tv in gres Fokos Piombo opaco. Vetrina con ante EVANS AIR in alluminio Oro rosa e vetro Fumè.

Library in Rovere TC, tv cabinet in gres Fokos Piombo opaco. EVANS AIR glass cabinets with aluminum doors in Rose Gold aluminum and Fumè glass.



Dettaglio Boiserie ALWAYS in legno Rovere TC rigato e porta ESP CORE. Tavolo YASS con struttura nero opaco e piano in gres Emperador opaco. Sedia BIG MAMA con struttura nero opaco e seduta in velluto Viky 09.

Detail of boiserie ALWAYS in Rovere TC. YASS table with black matt structure and tabletop in gres Emperador matt. BIG MAMA Chair with matt black frame and Viky 09 velvet seat.



# 12

## TECHNICAL DATA

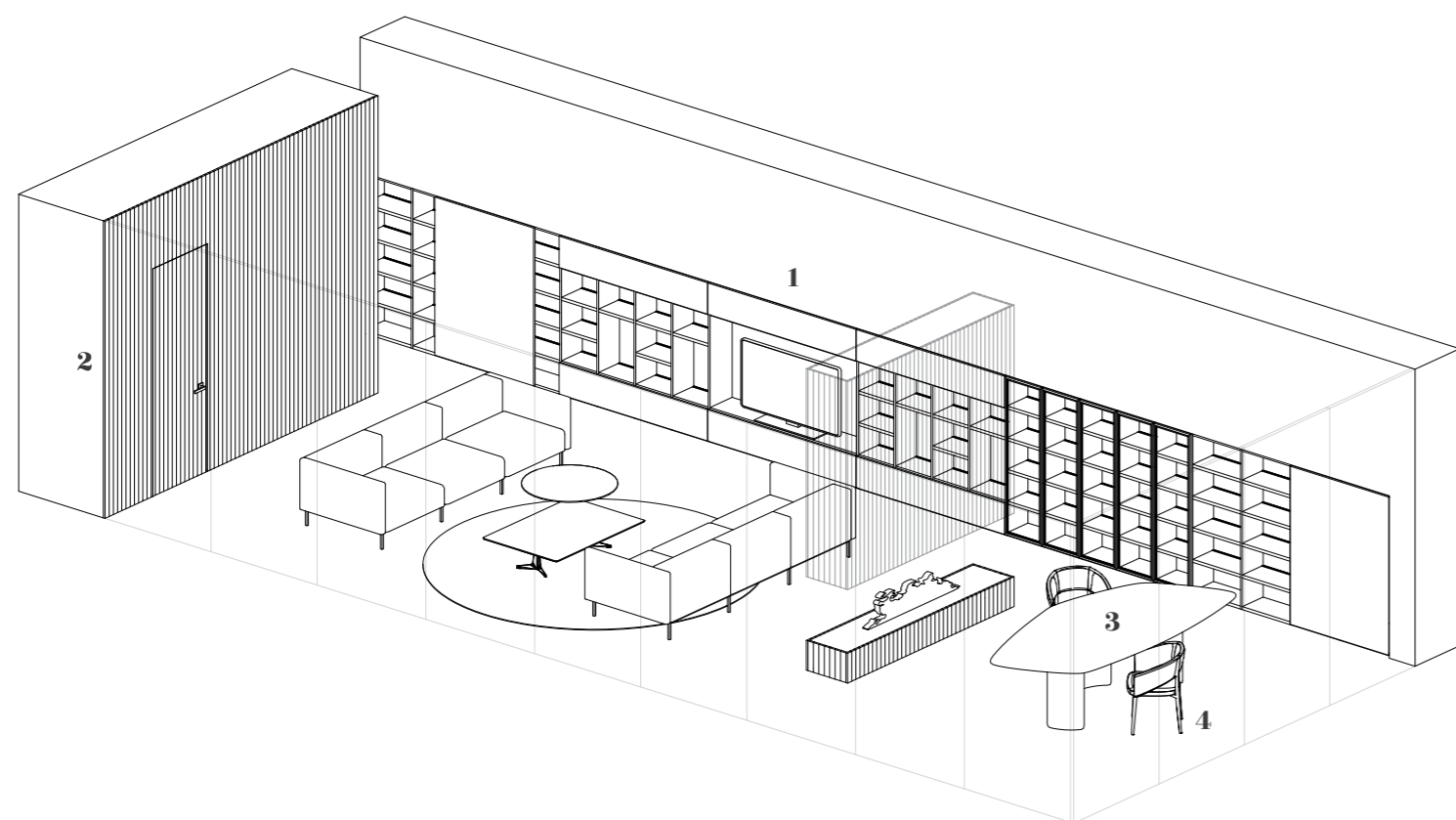

### 1 LIBRARY *libreria library*

Struttura e ante legno impiallacciato Rovere TC. Struttura vetrina legno impiallacciato Rovere TC e ante Evans Air alluminio Oro Rosa e vetro Fumè

Doors in Rovere TC finish, glass cabinet with structure in Rovere TC finish with Evans Air aluminum doors in Rose Gold finish and Fumè glass

### 2 ESP CORE ALWAYS *porta door*

Porta e boiserie Always in legno impiallacciato Rovere TC doga con maniglia Robocinques neromat

Door with Robocinques handle and boiserie Always in striped wood veneer Rovere TC finish

### 3 YASS *tavolo table*

Struttura laccato opaco nero e top gres Emperador opaco

Black matt structure and top in matt gres Emperador finish

### 4 BIG MAMA *sedia chair*

Struttura in legno nero opaco e seduta velluto Viky 09

Structure in matt black wood and Viky 09 velvet seat

13<sup>th</sup> STORY. HOUSE OF CLARINET





## 13<sup>th</sup> STORY

“Ho fatto tutto il possibile col clarinetto, se ci avessi fatto di più lo avrei sminuito”

“I did all you can do with a clarinet. Any more would have been less.”

Artie Shaw

---



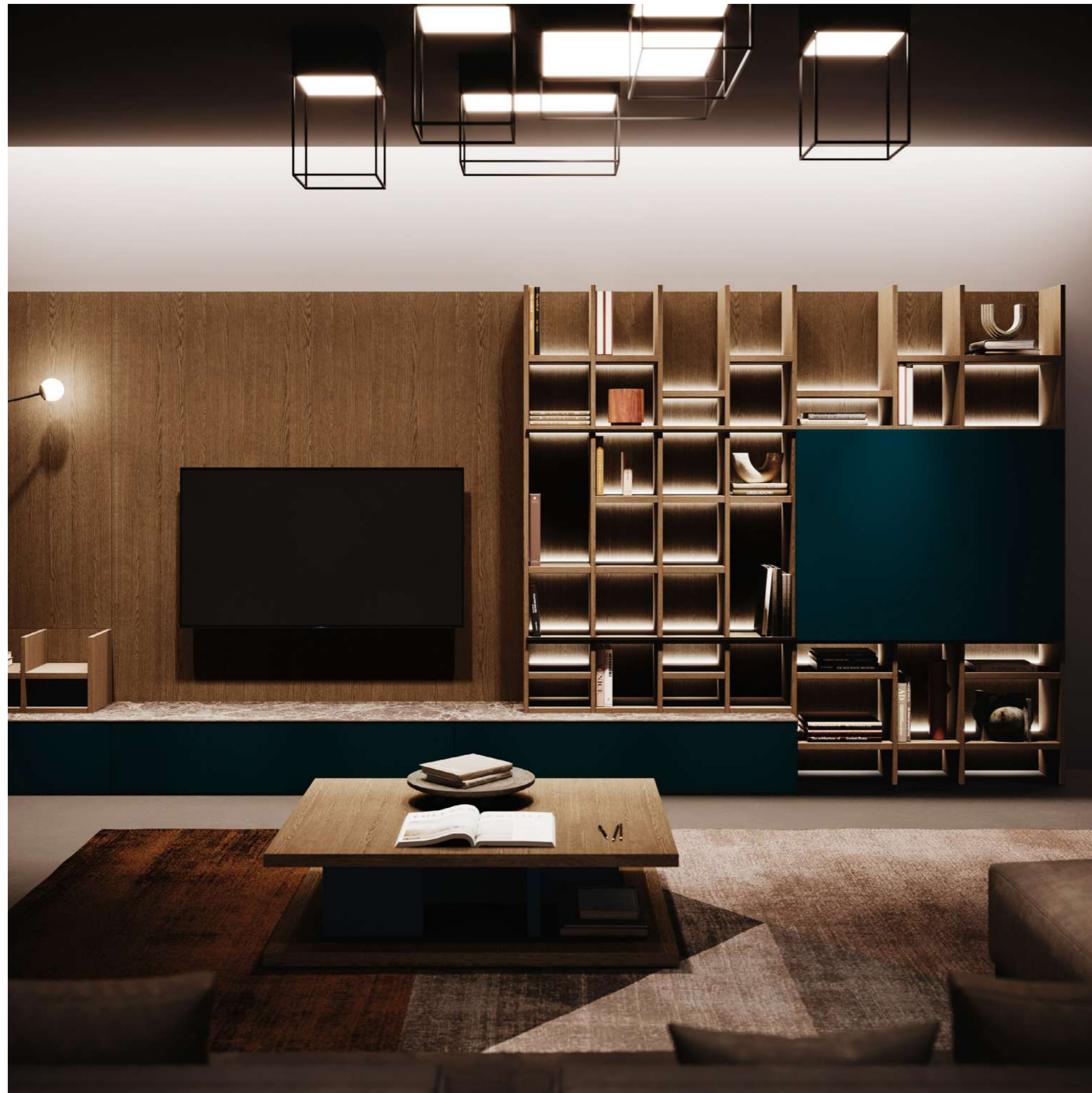

Libreria in legno Rovere FM, mobili contenitori laccato opaco Blu RE e piano in gres Emperador opaco. Coffee table ALFIE con piano in legno Rovere FM e divisori in laccato opaco Blu RE.

Library in veneer Rovere FM, cabinets in Blu RE lacquer and top in Gres Emperador matt. Coffee table ALFIE with top in Rovere FM veneer, dividers in matt Blu RE.

Madia DIVA con basamento nero opaco, ante laccato opaco Blu RE, piano in legno Rovere FM. Piano Folding in legno Rovere FM.

DIVA sideboard with matt black legs-frame, doors in matt lacquer Blu RE, piano in Rovere FM veneer, desk in veneer Rovere FM.

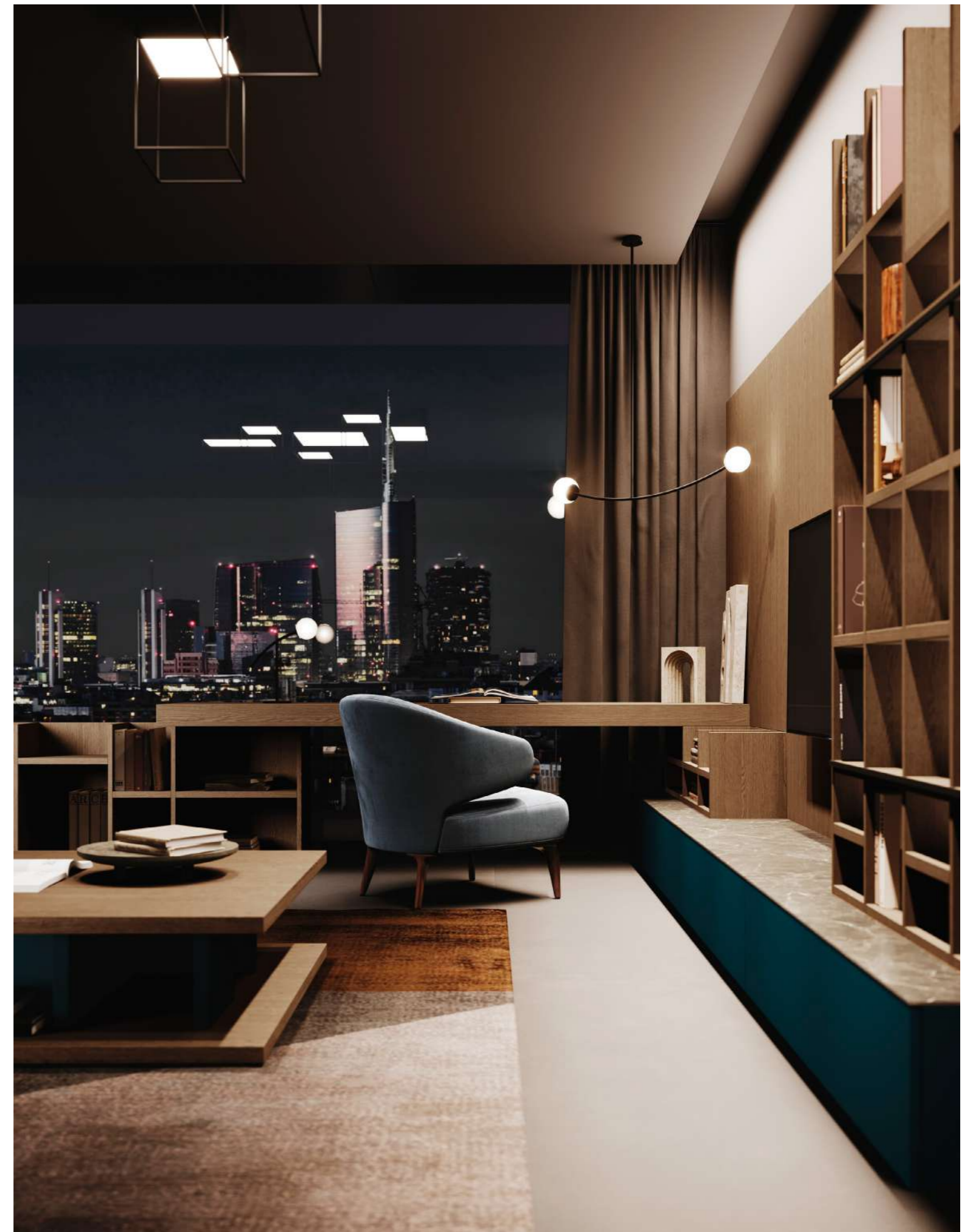

# 13

TECHNICAL DATA

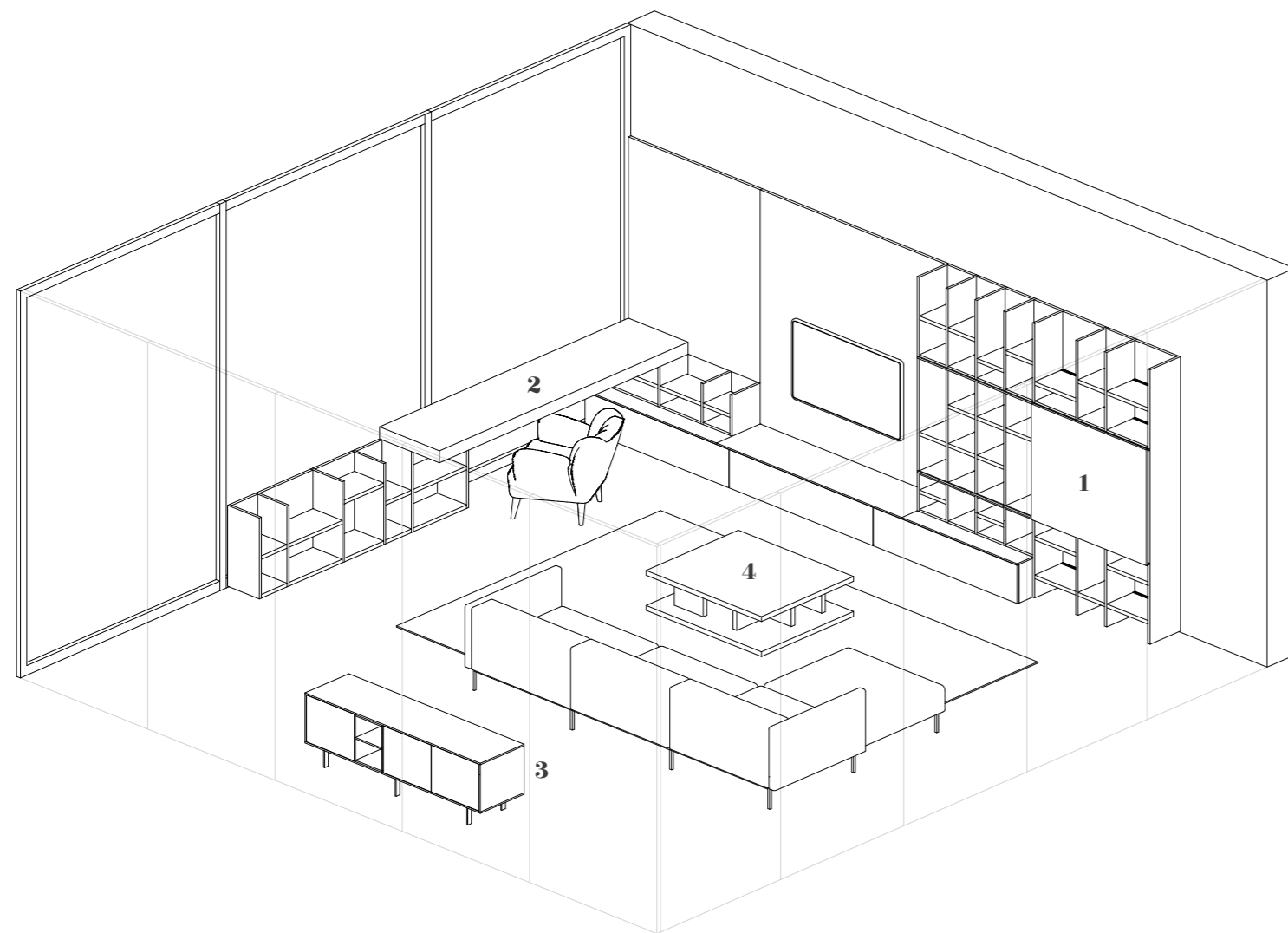

## 1 LIBRARY *libreria library*

Struttura legno impiallacciato Rovere FM e ante laccato opaco Blu RE

Structure in wood veneer Rovere FM finish and doors in matt lacquered Blu RE finish

## 2 FOLDING *piano desk*

Piano folding in legno impiallacciato Rovere FM

Folding desk in wood veneer Rovere FM finish

## 3 DIVA *madia sideboard*

Basamento metallo nero opaco con ante e top laccato opaco Blu RE e legno impiallacciato Rovere FM

Structure in metal black finish, doors and top in matt lacquered Blu RE finish, open unit in wood veneer Rovere FM finish

## 4 ALFIE *tavolino coffee table*

Piano legno impiallacciato Rovere FM e divisori laccato opaco Blu RE

Top in wood veneer Rovere FM finish, dividers in matt lacquered Blu RE finish

14<sup>th</sup> STORY. HOUSE OF VOCALS



# 14<sup>th</sup> STORY

"The only thing better than singing is more singing"

"L'unica cosa più bella che cantare è cantare ancora"

Ella Fitzgerald

---







Libreria laccato opaco Cappuccino LO con schienali legno Rovere VS rigato. Armadio FLAT laccato opaco Cappuccino LO e mobili contenitori ALWAYS laccato opaco Grigio AT rigato.

Library matt lacquer Cappuccino LO with back panels in striped Rovere VS. FLAT wardrobe matt lacquer Cappuccino LO and ALWAYS cabinets with matt lacquer Grigio AT striped.

Madia MISTY TRAY con struttura nero opaco e ante EVANS AIR in alluminio nero e vetro Fumè Seamless. Tavolo OTIS con basamento in legno Rovere TC rigato e piano in gres Pietra di Savoia grigio fiammato. Sedia BIG MAMA con struttura nero opaco e seduta in velluto Viky 10.

Misty tray with black matt structure and EVANS AIR doors in black aluminum with Fumè glass in Seamless pattern. Table OTIS with wood basement in striped Rovere TC and tabletop in gres Pietra di Savoia grey veined. BIG MAMA Chair with matt black frame and Viky 10 velvet seat.



# 14

## TECHNICAL DATA

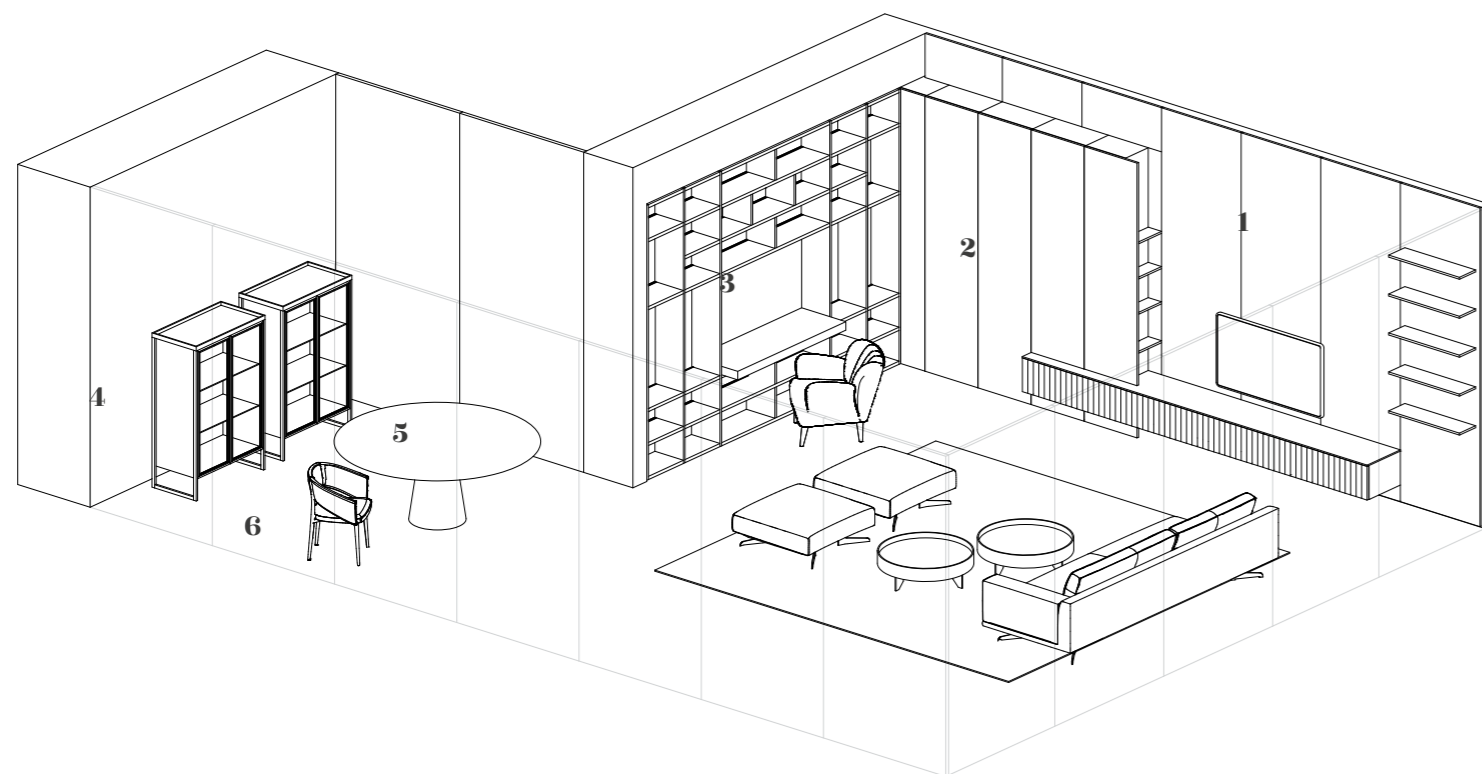

### 1 LIVING *mobili contenitori* modules

Struttura bilaminato Lino Grey e ante Always laccato opaco Grigio AT. Boiserie Always in legno Rovere VS

Structure in bilaminate Lino Grey finish and Always doors in matt lacquered Grigio AT finish. Boiserie Always in wood veneer Rovere VS finish

### 2 FLAT *armadio* wardrobe

Struttura bilaminato Lino Grey e ante laccato opaco Cappuccino LO

Structure in bilaminato Lino Grey finish and doors matt lacquered Cappuccino LO finish

### 3 LIBRARY *libreria* library

Struttura laccato opaco Cappuccino LO, schiene e piano desk legno impiallacciato Rovere VS con effetto rigato

Structure matt lacquered Cappuccino LO finish with back panels in striped wood veneer Rovere VS finish and cabinets with striped matt lacquered Grigio AT finish

### 4 MISTY TRAY *madia* sideboard

Struttura in alluminio nero opaco e vassoio laccato opaco Nero. Ante Evans Air in alluminio nero opaco e vetro Fumè seamless

Structure in aluminium with tray in matt lacquered black finish and Evans Air doors in black aluminum with Fumè glass in seamless pattern

### 5 OTIS *tavolo* table

Struttura legno Rovere TC rigato e piano in gres Pietra di Savoia grigia

Structure in striped wood veneer Rovere TC finish and top in matt gres Pietra di Savoia grey finish

### 6 BIG MAMA *sedia* chair

Struttura in legno nero opaco e seduta velluto Viky 10

Structure matt black wood and grey velvet Viky 10 seat

15<sup>th</sup> STORY. HOUSE OF TROMBONES





## 15<sup>th</sup> STORY

"Quando soffi da un estremità del trombone dall'altra esce un suono che sconquassa il cosmo"

"You blow in this end of the trombone and sound comes out the other end and disrupts the cosmos."

Roswell Rudd

---





Libreria in bilaminato legno Mandorlo con ante laccato lucido Caffè OP e vetrine EVANS AIR in alluminio Bronzo e vetro Fumè, cassetti in eco-pelle Pandora O4 e schienali in gres Stone Brown opaco.

Library in Bilaminated Mandorlo with high gloss lacquer doors in Caffè OP and EVANS AIR glass doors in Bronze aluminum and Fumè glass, drawers in eco-leather Pandora O4 and back panels in matt gres Stone Brown.

Madia ELLINGTON & Base con  
basamento bronzo, ante laccato lucido  
Caffè OP, piano in laccato Bronzo.

ELLINGTON & Base Cupboard with  
bronze color legs-frame, doors in Caffè  
OP, top panel in lacquered Bronze.



# 15

TECHNICAL DATA

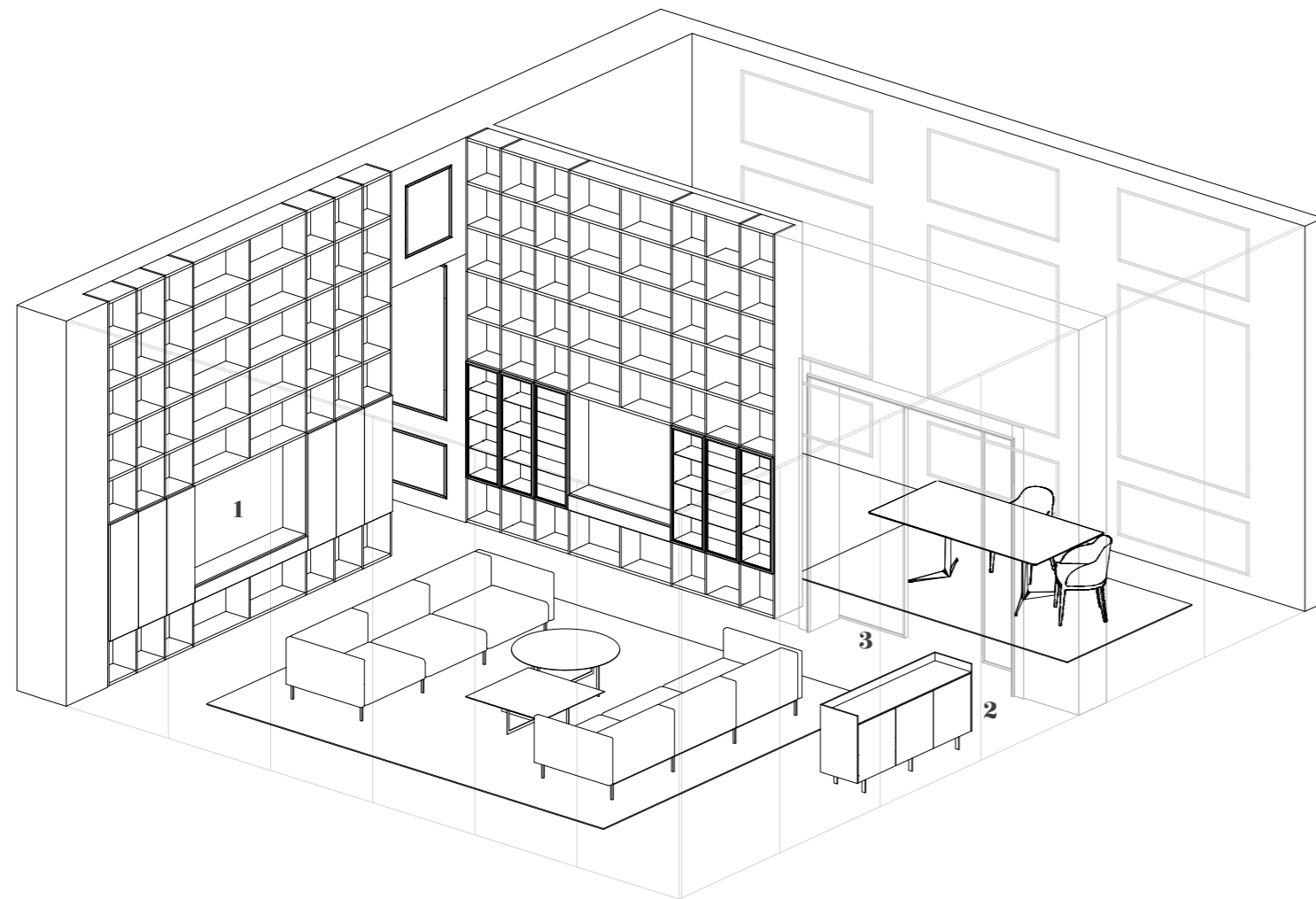

## 1 LIBRARY *libreria library*

Struttura bilaminato legno Mandorlo. Ante laccato lucido Caffè OP e eco-pelle Pandora 04. Ante Evans Air alluminio Bronzo e vetro Fumè

Structure in wood bilaminate Mandorlo finish. Doors in high gloss lacquered Caffè OP finish and eco-leather Pandora 04 finish. Evans Air glass doors in Bronze anodized aluminum and Fumè glass

## 2 ELLINGTON AND BASE *media sideboard*

Basamento metallo bronzo con ante laccato lucido Caffè OP e top laccato Bronzo

Structure in metal Bronze finish with doors in high gloss lacquered Caffè OP finish, top panel in glossy lacquered Bronze finish

## 3 ESP CRISTAL *porta door*

Porta alluminio nero e vetro extra clear con maniglia Lambda

Door in aluminum black finish and extra clear glass with Lambda handle



## STRUTTURE STRUCTURES

**STR Bilaminato bilaminato**

Bilaminato materico finitura liscio, tessuto e legno

Materic bilaminato available plain color, fabric or wood finish

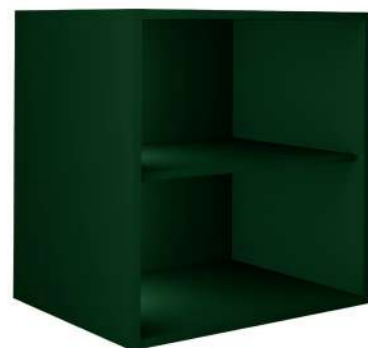
**LOP Laccato opaco matt lacquered**

Laccato opaco 6 lati su base bilaminato, disponibile in tutti i colori di serie

Matt lacquered 6 sides on bilaminato panel, available in all price list finishes

**LMT Laccato metallico liscio smooth metal lacquered**

Laccato effetto metallico liscio 6 lati su base bilaminato, disponibile in tutti i colori di serie

Smooth metal lacquered 6 sides on bilaminato panel, available in all price list finishes

Sistema bussolotto - I fianchi di spessore 18 mm vengono forati ogni 160 mm di modo da consentire il posizionamento dei ripiani spostabili. Ogni base è provvista di piede regolabile o attaccaglie. Capello, base e ripiani sono di spessore 18 mm. Schienale di spessore 4 e 8 mm.

Single module system - Side panels thickness 18 mm, hole distance 160 mm for removable shelves. Bottom adjustable feet or hanging system. Top, bottom and shelves thickness 18 mm. Back panels thickness 4 or 8mm.

**LMG Laccato metallico graffiato brushed metal lacquered**

Laccato effetto metallico graffiato 6 lati su base bilaminato, disponibile in tutti i colori di serie

Brushed metal lacquered 6 sides on bilaminato panel, available in all price list finishes

**LEG Impiallacciato wood veneer**

Legno impiallacciato 6 lati, disponibile in tutti i colori di serie

Wood veneer 6 sides, available in all price list finishes

**LEE Impiallacciato esotico exotic wood veneer**

Legno impiallacciato esotico 6 lati, disponibile in tutti i colori di serie

Exotic wood veneer 6 sides, available in all price list finishes

Librerie - I fianchi di spessore 22 mm vengono forati ogni 160 mm di modo da consentire il posizionamento dei ripiani spostabili. Ogni base è provvista di piede regolabile o attaccaglie. Capello, base e ripiani sono di spessore 30 mm. Schienale di spessore 8 mm.

Bookshelves - Side panels thickness 22 mm, hole distance 160 mm for removable shelves. Bottom are equipped with adjustable feet or hanging system. Top, bottom and shelves thickness 30 mm. Back panels thickness 8mm.

**MODULARITÀ SISTEMA BUSSOLOTTO MODULARITY**

**P / D profondità disponibili available depth**

Le dimensioni dei mobili sono espresse escluse di ante.

Cabinet dimensions are expressed without doors.

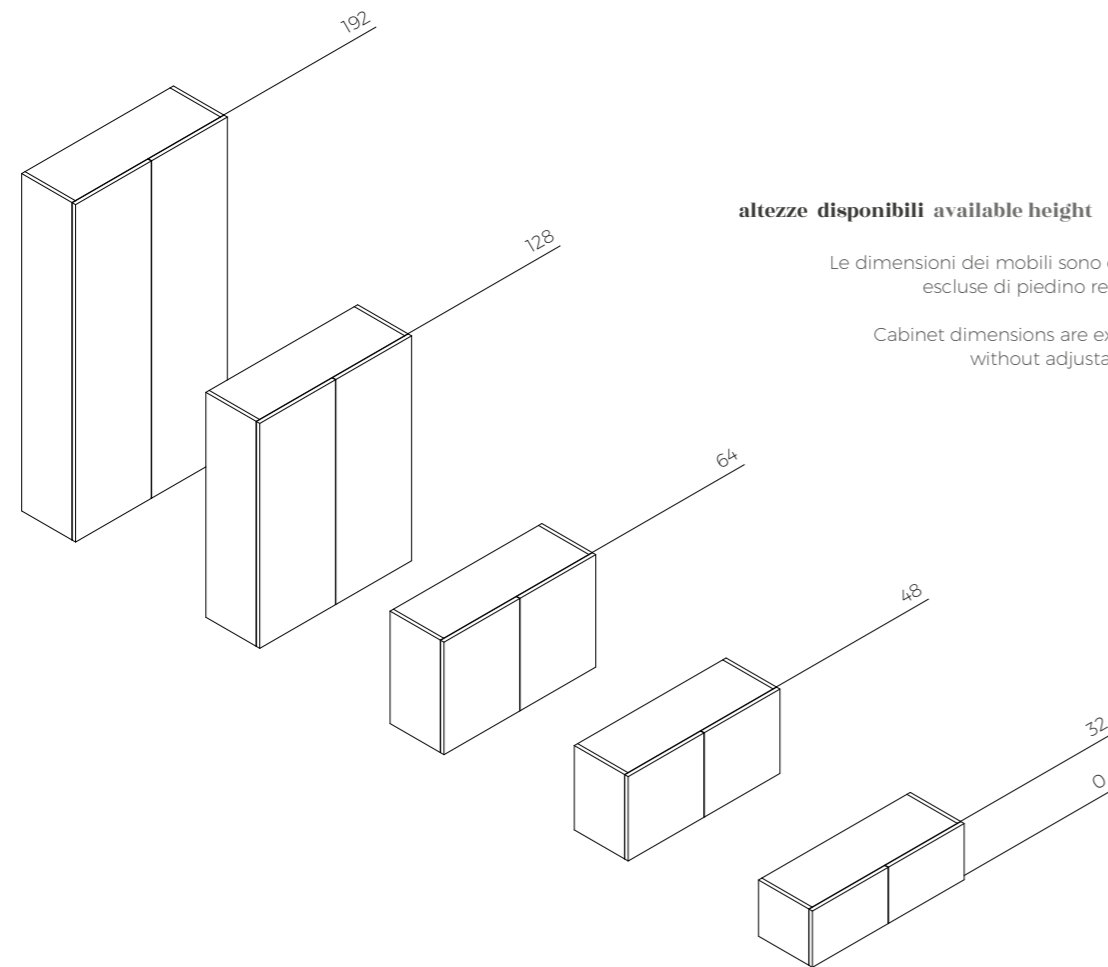
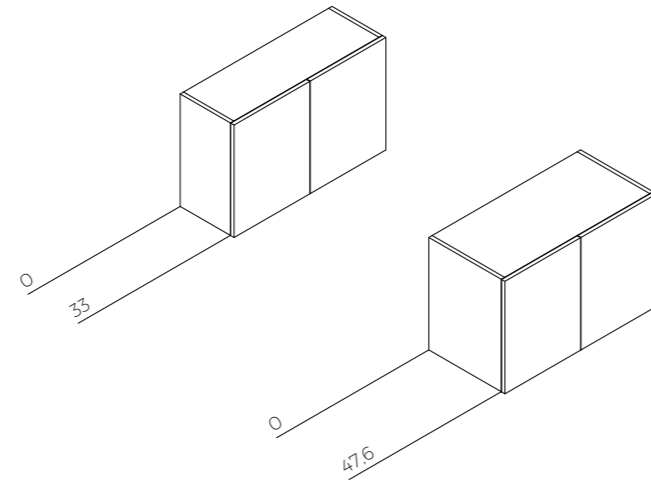

**altezze disponibili available height A / H**

Le dimensioni dei mobili sono espresse escluse di piedino regolabile.

Cabinet dimensions are expressed without adjustable foot.

**larghezze disponibili available width L / W**

Le dimensioni dei mobili sono da intendersi comprensive di fianchi.

Wardrobe dimensions are expressed included of side panels.

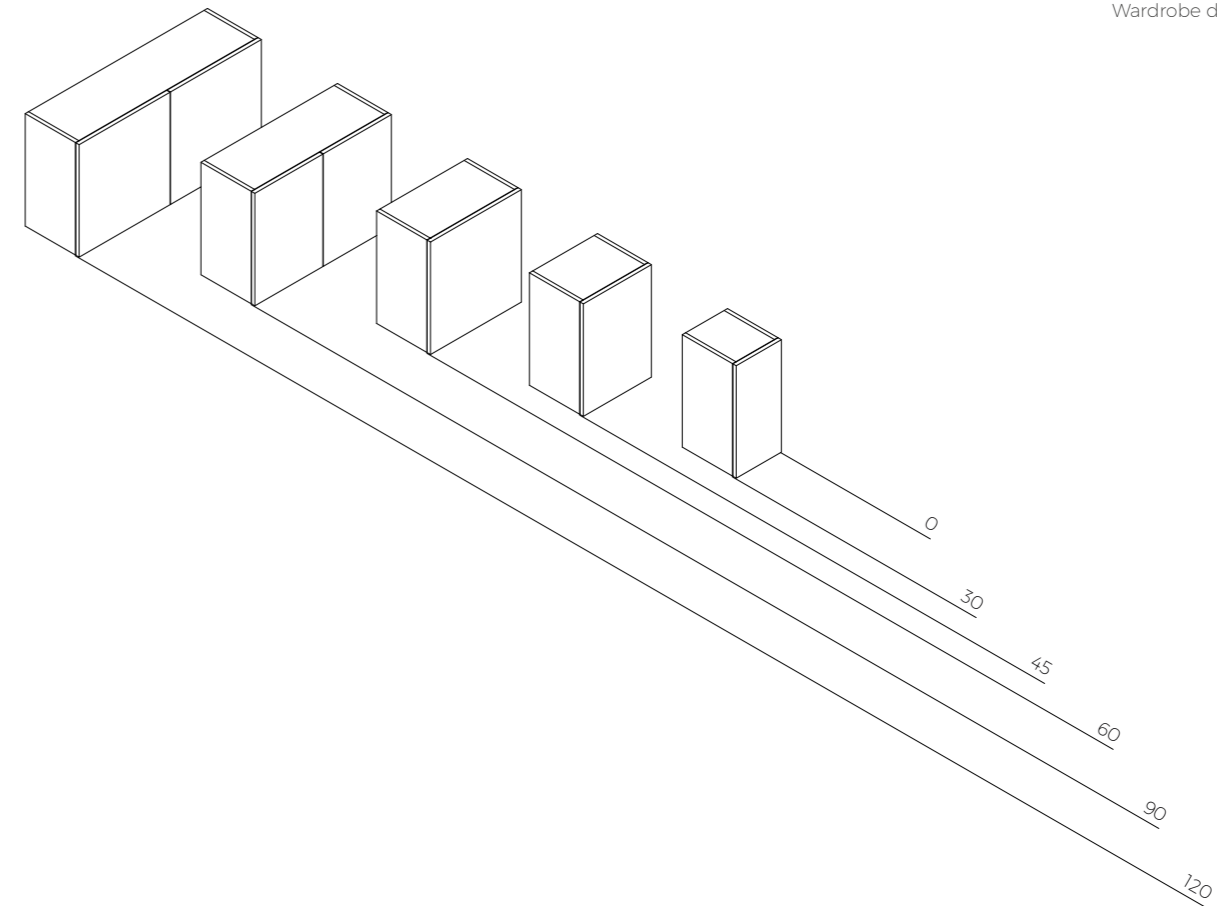

**TIPOLOGIE DI APERTURA OPENING SYSTEMS**

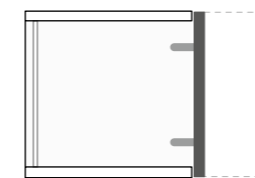

ANTA BATTENTE  
hinged door

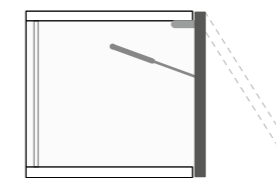

ANTA VASISTAS  
vasistas door

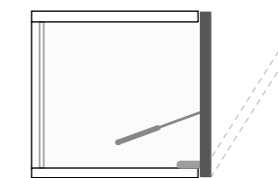

ANTA RIBALTA  
flap door

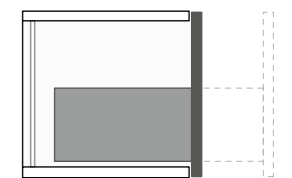

ANTA CASSETTO/CESTONE  
drawer/basket door

**MODULARITÀ LIBRERIE MODULARITY**

**P / D profondità disponibili available depth**

Le dimensioni dei mobili sono espresse escluse di ante.

Cabinet dimensions are expressed without doors.

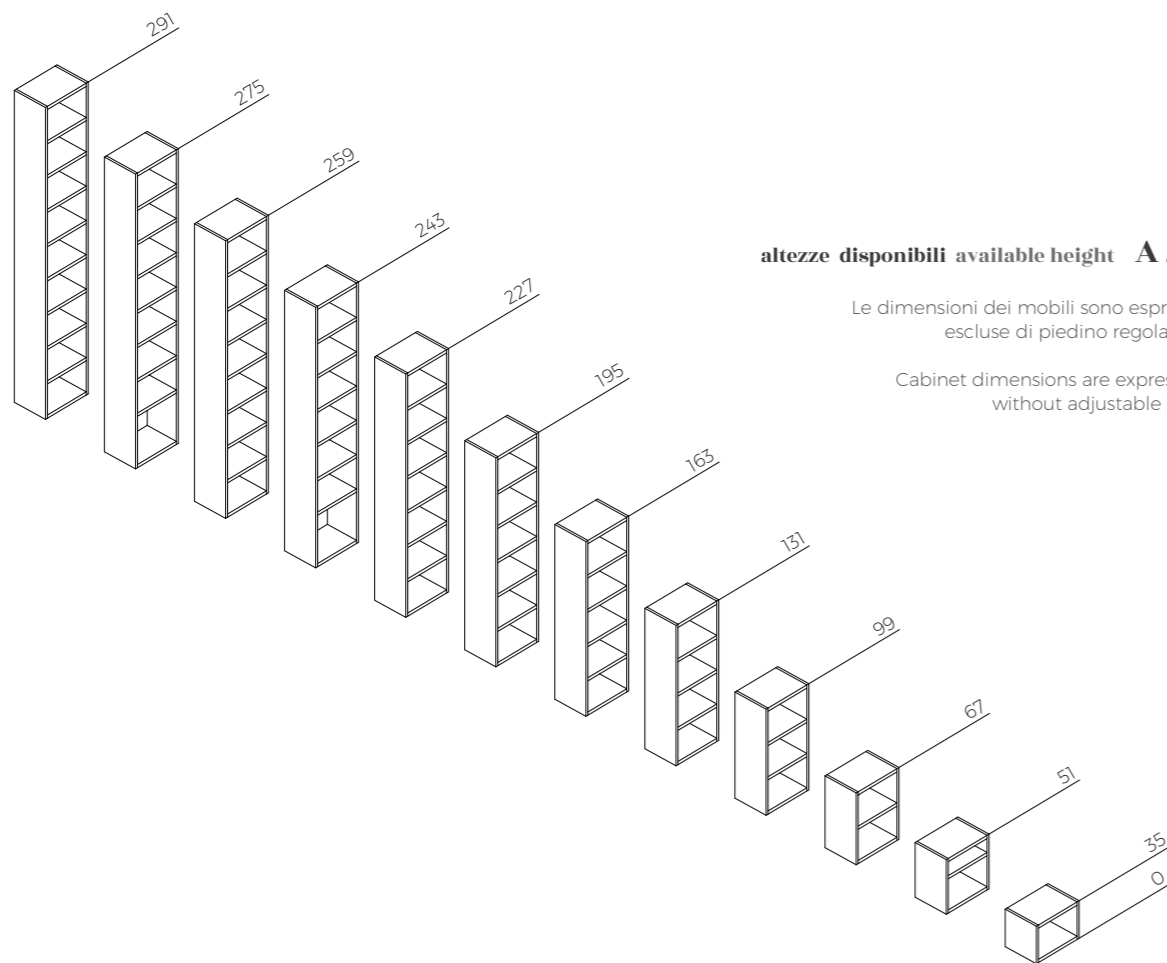
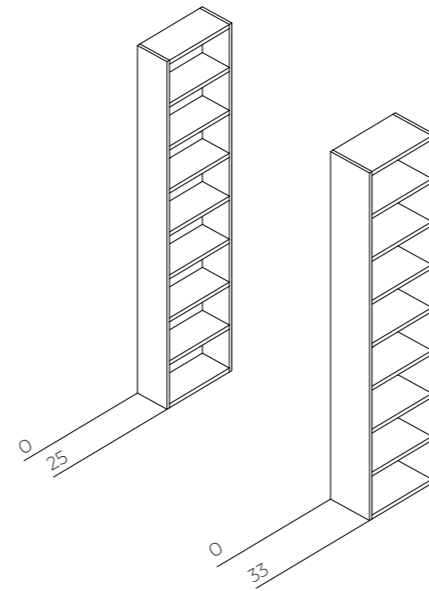

**altezze disponibili available height A / H**

Le dimensioni dei mobili sono espresse escluse di piedino regolabile.

Cabinet dimensions are expressed without adjustable foot.

**larghezze disponibili available width L / W**

Le dimensioni dei mobili sono da intendersi per il solo modulo interno, escluso di tramezzi e/o fianchi.

Wardrobe dimensions are expressed only for the internal module, excluded of partition panels and/or side panels.

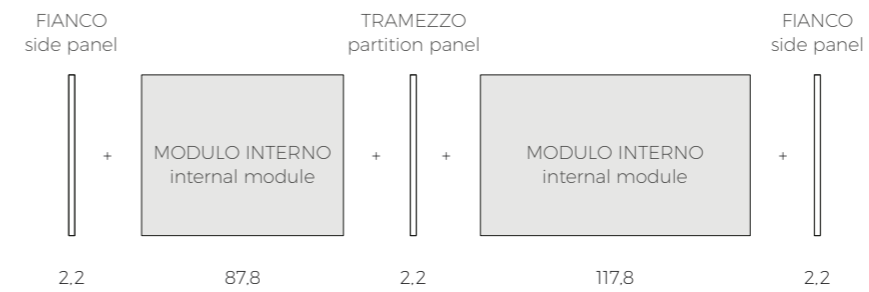
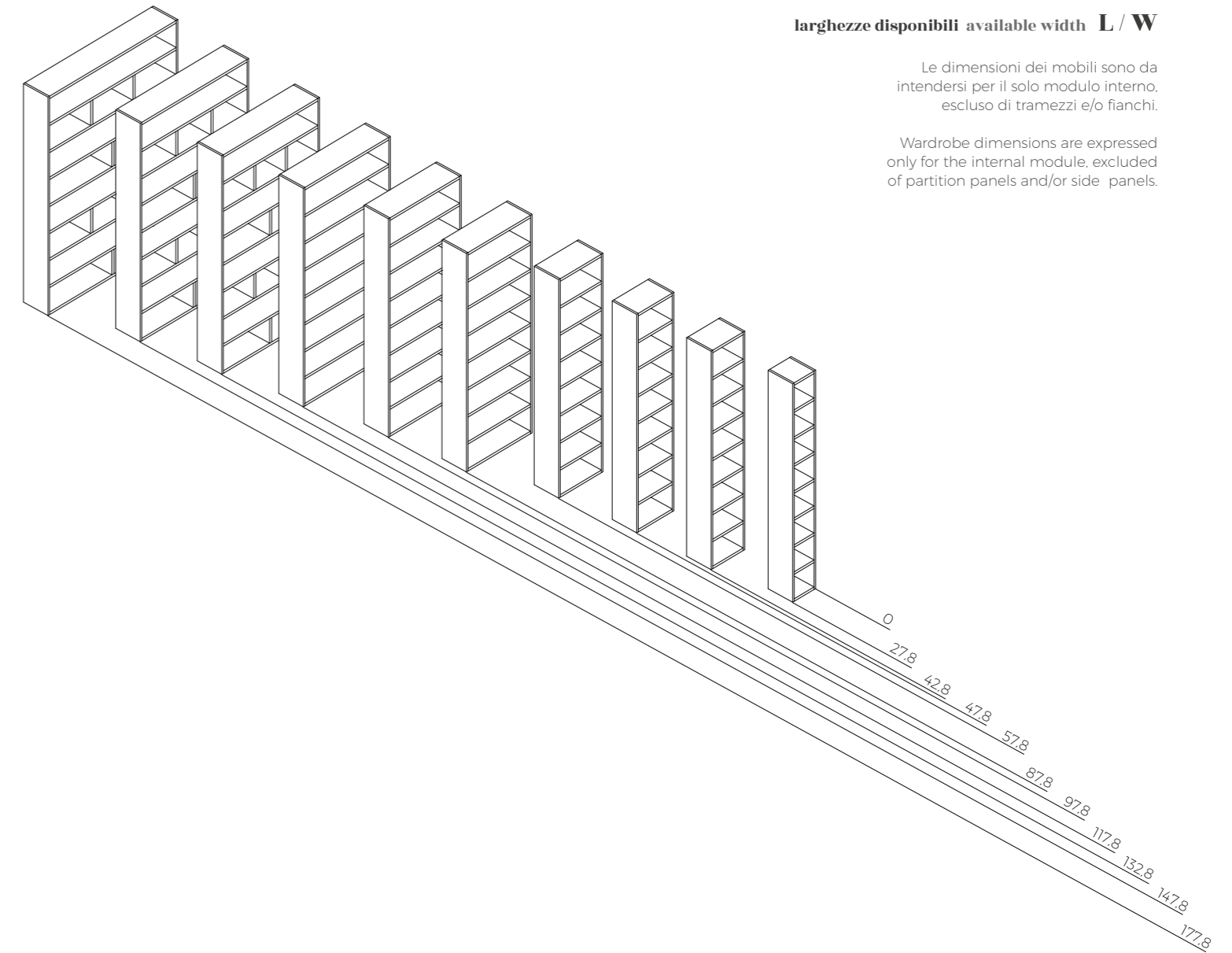

Per progettare la tua composizione aggiungi ai moduli scelti i relativi tramezzi e/o fianchi.

To design your composition, add the relevant partition panels and/or side panels to the chosen modules.

Art direction  
Mama Studio

Graphic design  
Mama Studio

Product design  
Mama Studio  
Giuseppe D'Ecclesia

Copy  
Mama Studio  
Gabriella Cerulli

Render  
Matic animation

Color separation  
Francesca Di Giovanni

Print  
Sincromia

Thanks to  
MM Lampadari

GUZZINI & FONTANA PROJECTS S.R.L.  
Via Grecia - Palazzese, Roseto degli Abruzzi  
64026 (TE) Italy  
Cod. Fisc. / P.IVA 01927160679  
Tel. +39 085 8069006  
info@guzziniefontana.it



The mark of  
responsible forestry  
FSC® C136814



Guzzini & Fontana project s.r.l. può apportare ai prodotti modifiche, migliorie tecniche, annullamenti di articoli di fine serie che siano ritenuti opportuni, in qualsiasi momento e senza alcun preavviso.  
Guzzini & Fontana project s.r.l. reserves the right to modify its products, apply technical improvements or cancel end-of-series articles when deemed opportune and at any time, without prior notice.